

POWER ELECTRICAL BOX (15)
VOIR / SEE SHEET 3/4
(DETAILED ELECTRICAL CONNECTION)

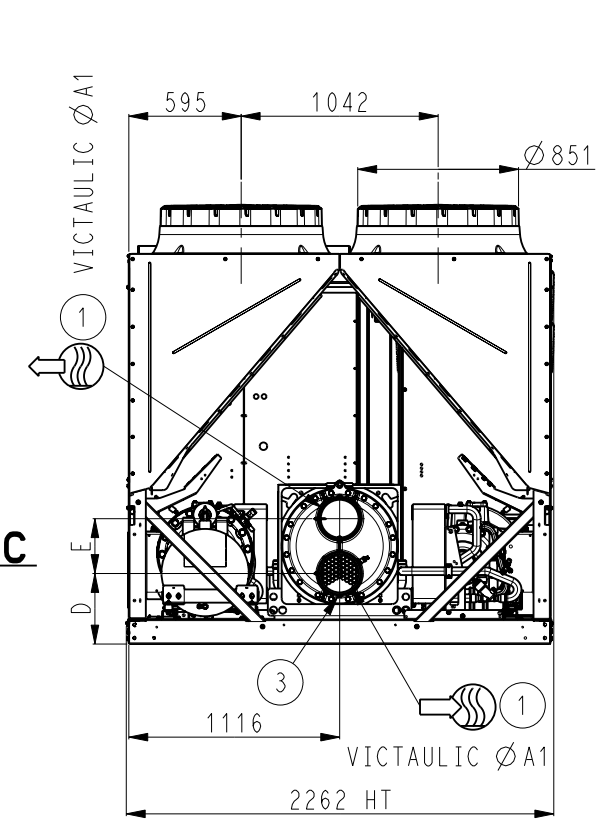

VOIR / SEE SHEET 3/4
(DETAILED ELECTRICAL CONNECTION)

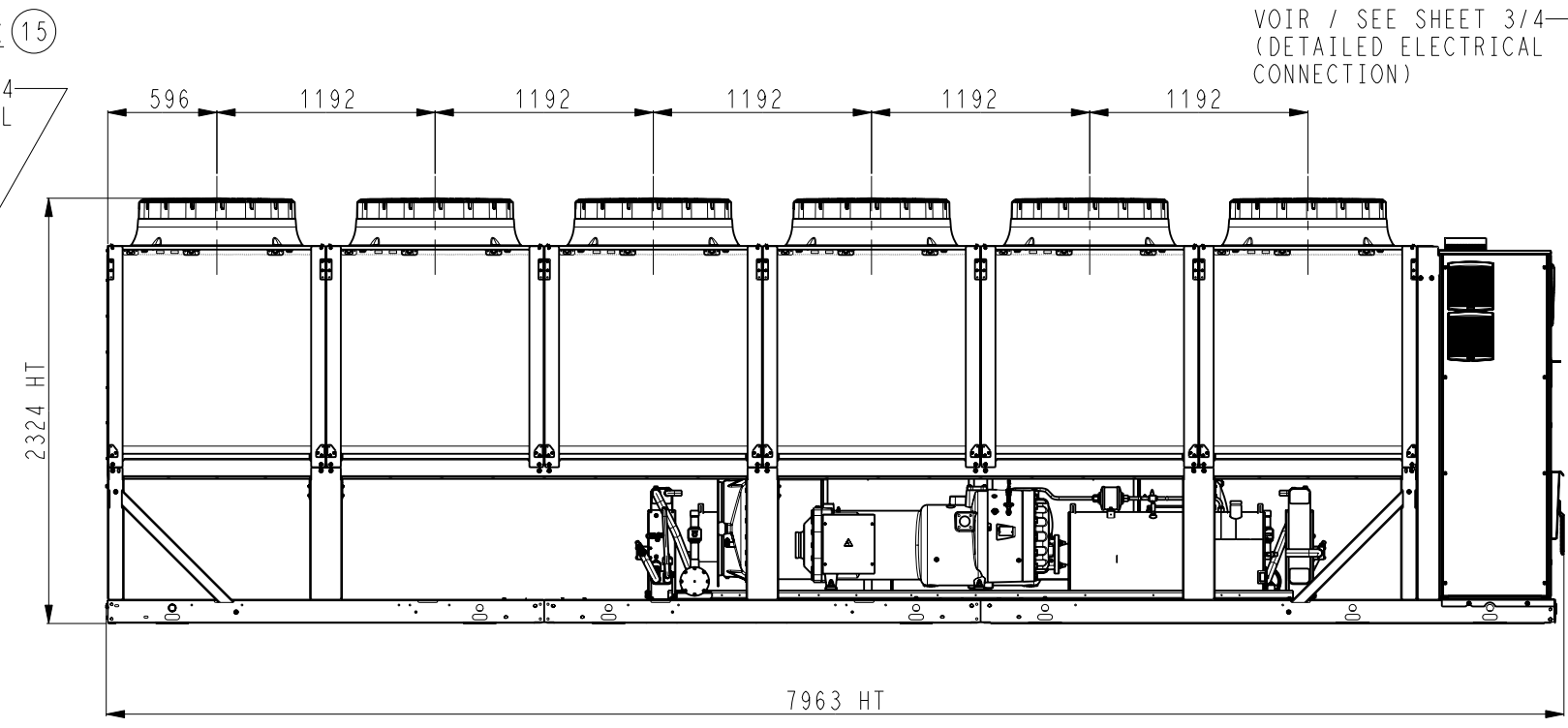
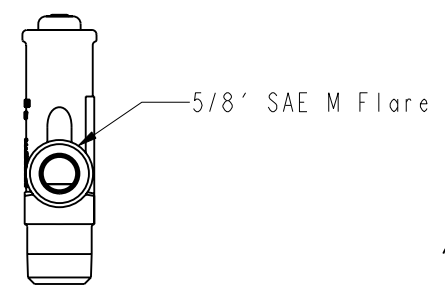
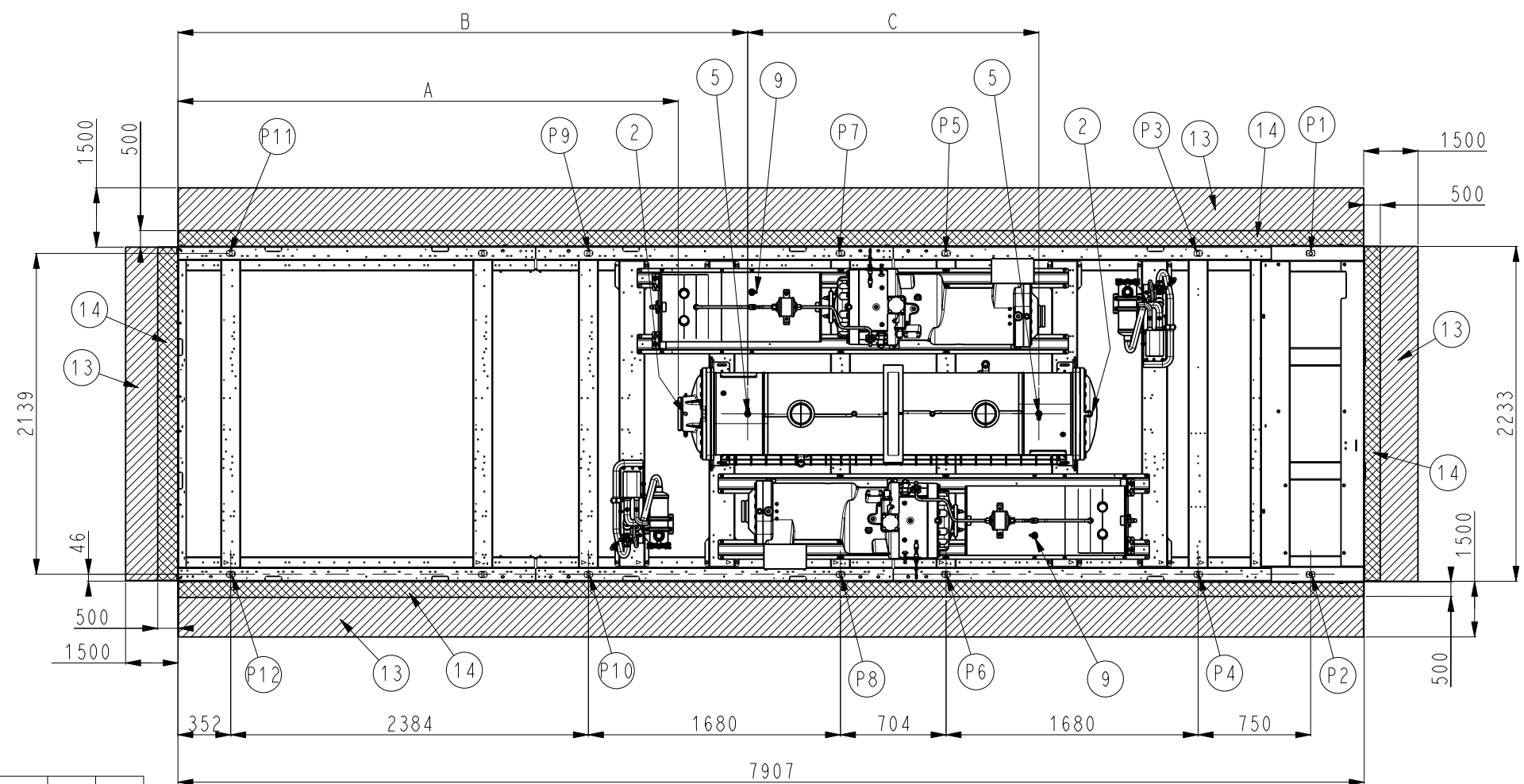

DETAIL SOUPAPE 5

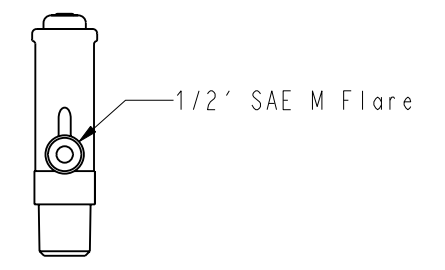

DETAIL SOUPAPE 9

UNITS	ØA1
3	9
30KAVZE 0650	
30KAV 1000 30KAVZE 0750	219.1

UNITS		A	B	C	D	E
KAV						
1000		3335	3798	1941	373	290

TOLERANCE ±10	30KAV 0720 OPT 119; 30KAV 0900/1000 30KAVZE 0550 OPT 119; 30KAVZE 0650/0750 30KAVP 0720 30KAVPZE 0550
------------------	--

Carrier
DATE 13-May-19
00DCG000260000
Feuille Sheet 1/5
Indice C

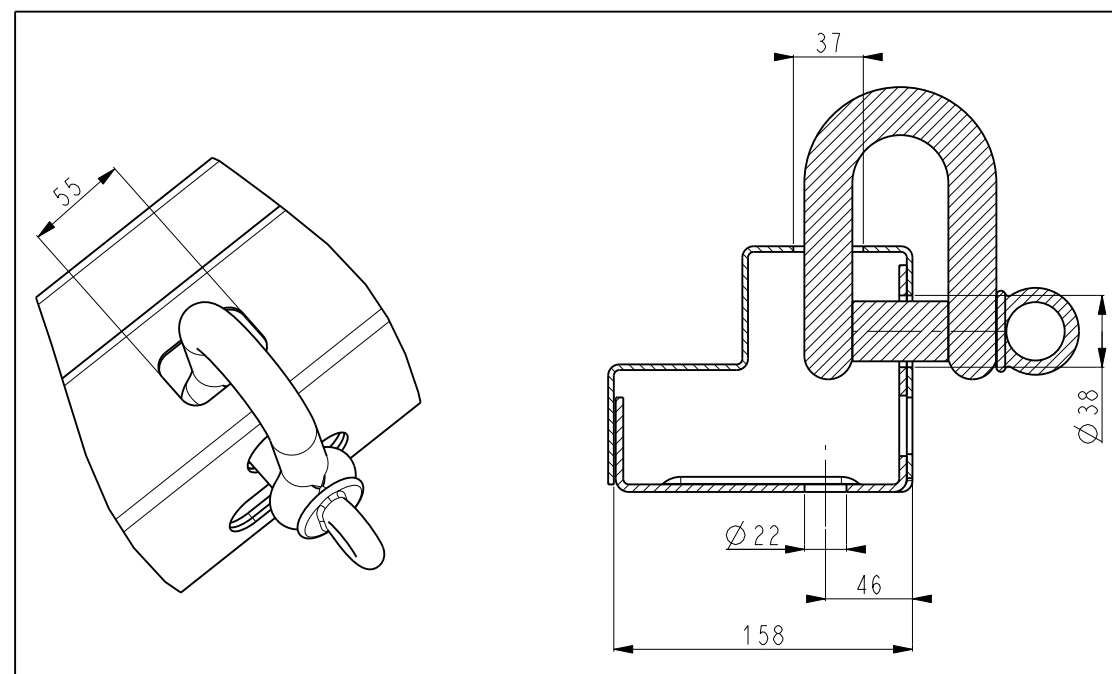
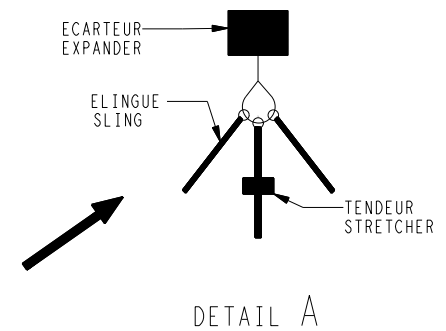
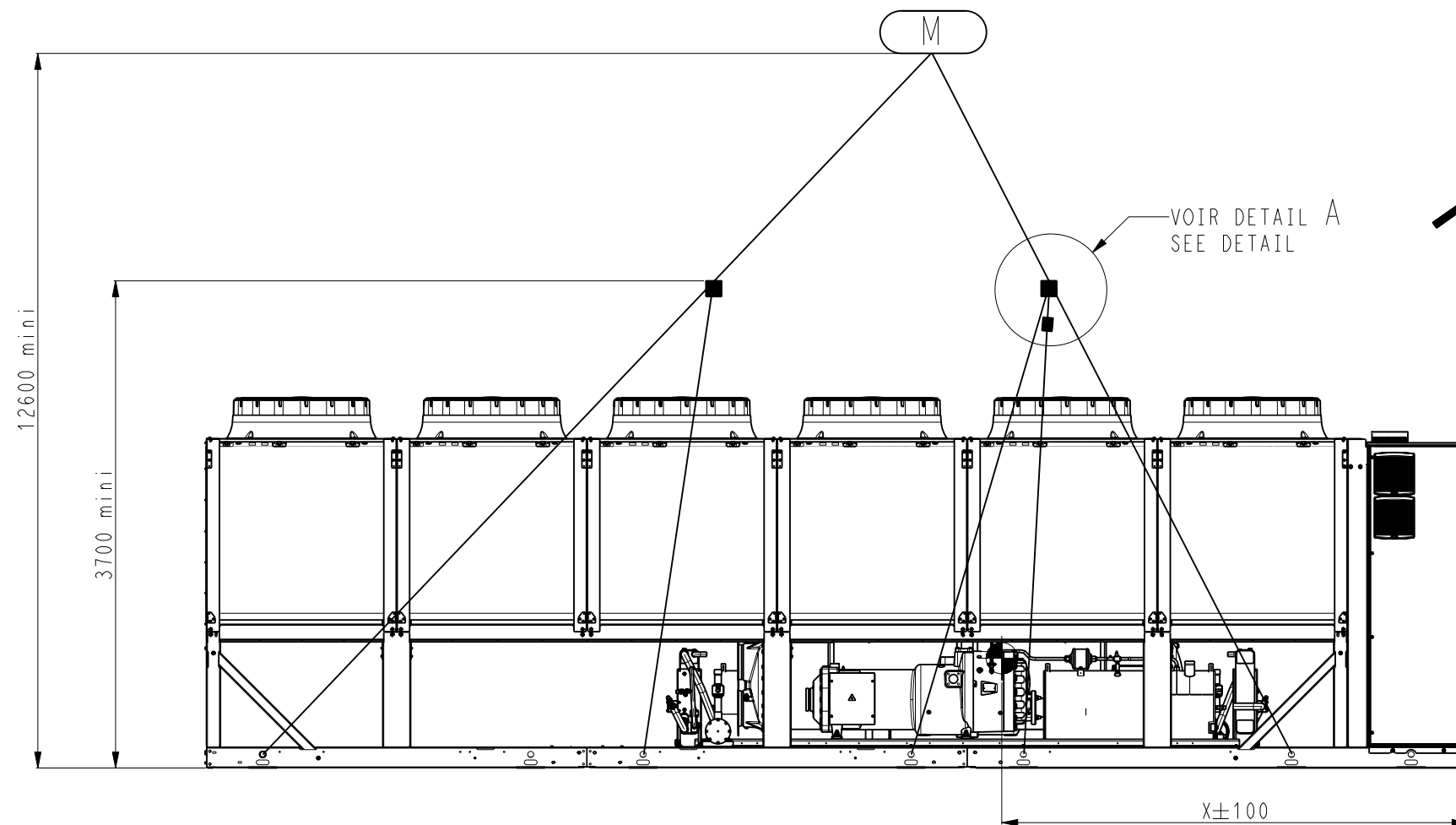
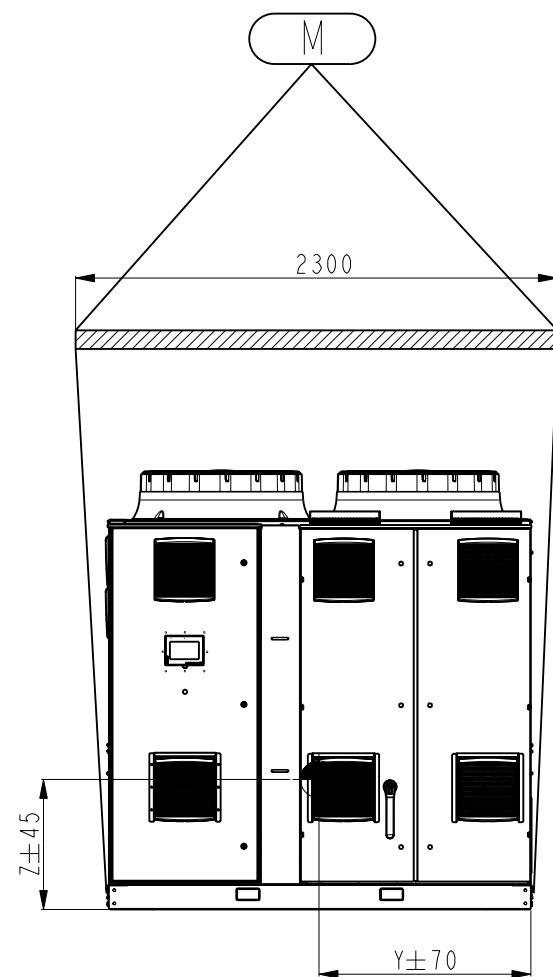

UNITS		X	Y	Z
	30KAV			
	1000	2912	1110	667

ELECTRICAL BOX : POWER CONNECTION FOR 30KAV 1000

STANDARD

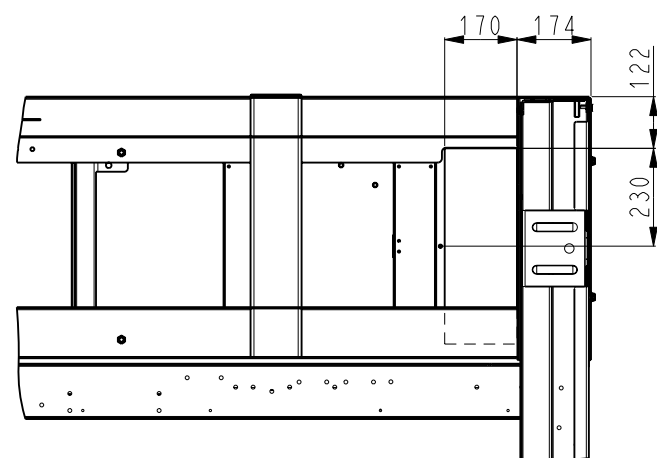

VUE / VIEW A

OPTION 70D

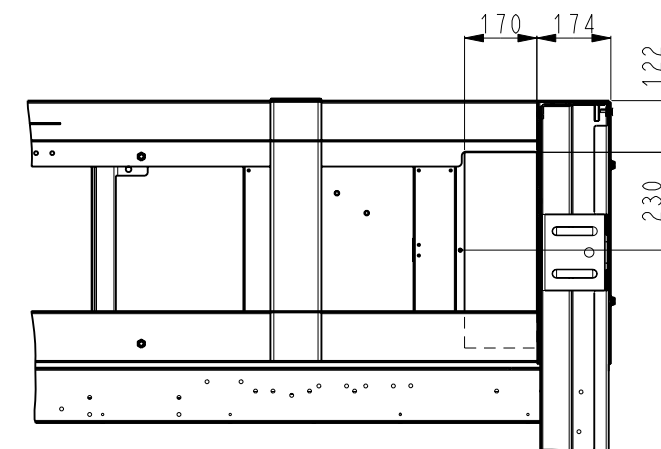

VUE / VIEW A

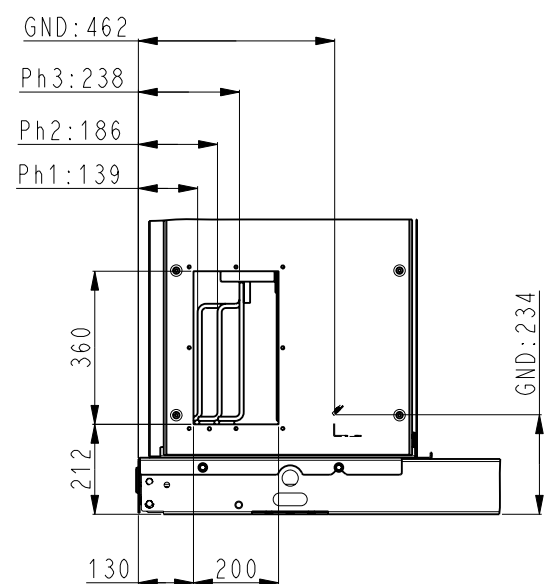

VUE / VIEW B

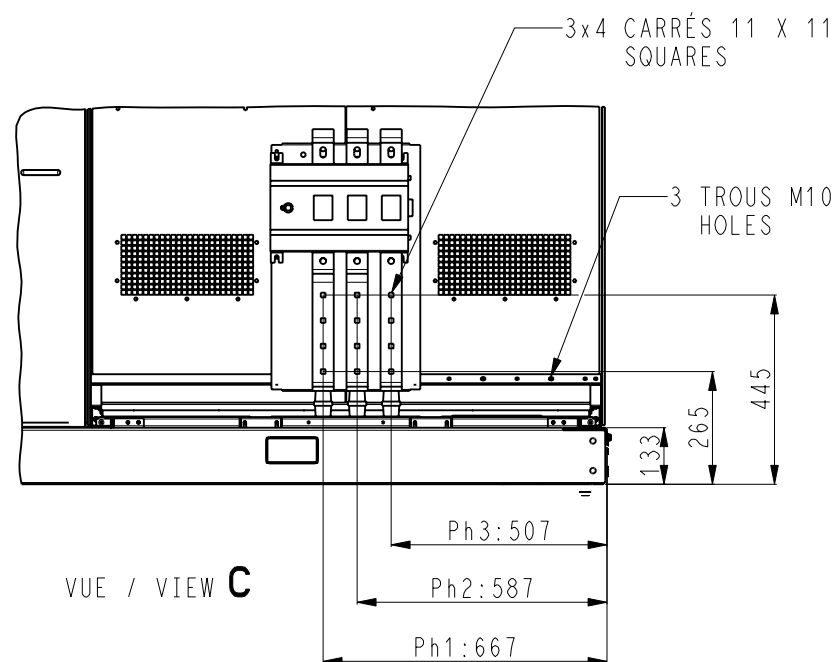

VUE / VIEW C

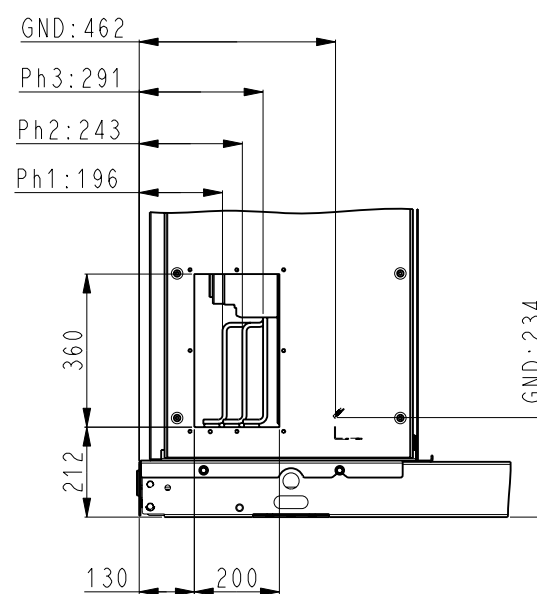

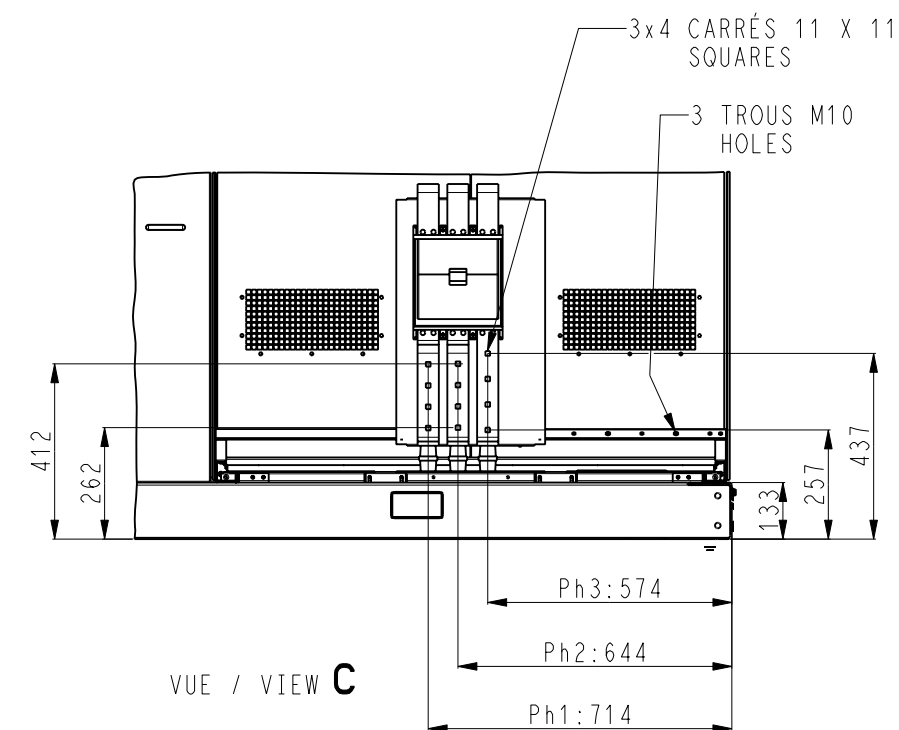

VUE / VIEW B

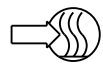
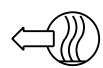

VUE / VIEW C

TOLERANCE ±10	30KAV 0720 OPT 119;30KAV 0900/1000		DATE	Feuille Sheet 4/5 Indice C
	30KAVZE 0550 OPT 119;30KAVZE 0650/0750		13-May-19	
	30KAVP 0720			
	30KAVPZE 0550			
		00DCG000260000		

	ENGLISH			
① →	Cooler water inlet and outlet			
② →	Cooler air vent			
③ →	Water drain			
④ →	NA			
⑤ →	Safety relief valve LP			
⑥ →	NA			
⑦ →	NA			
⑧ →	NA			
⑨ →	Safety relief valve HP			
⑩ →	NA			
⑪ →	NA			
⑫ →	NA			
⑬ →	Services clearances required			
⑭ →	ATEX ZONES (ZE UNITS ONLY)			
⑮ →	Electrical box			
⑯ →	Main disconnect switch			
⑰ →	NA			
PT →	Total operating weight			
	Inlet water			
	Outlet water			
	Electrical supply entry			
	Center of gravity			
(M)	Handling Rigging of the unit: the sizing of the rigging or lifting elements is the responsibility of the installer			