



PRODUCT SELECTION DATA

VARIABLE-SPEED SCREW LIQUID CHILLER WITH GREENSPEED™ INTELLIGENCE



Outstanding performance

Low sound levels

Intelligence and connectivity

Environmentally responsible

Wide range of applications

Simple installation and maintenance

30KAV 500 - 1100 30KAVP 500 - 1100

AQUAFORCE greenspeed

Nominal cooling capacity 493-1079 kW

The AquaForce™ Vision 30KAV/30KAVP liquid chillers with Greenspeed™ Intelligence are the premium solution for commercial and industrial applications where installers, consultants and building owners require superior reliability and optimal performances, especially at part load.

The 30KAV/30KAVP units are designed to exceed European Ecodesign directive requirements in terms of energy efficiency, versatility and operating sound levels. This result is achieved through the optimised combination of proven best-in-class technologies that include:

- 2nd generation of high-efficiency variable-speed twin screw compressors with built in volume index control (Vi) valve for optimal full and part load performance and Integrated Resonator Array (IRA) for low sound operation
- 30KAVP premium efficiency with a Permanent Magnet technology motor. Motor is synchronous and spins without any slip and rotor losses.
- 6th generation of Carrier Flying Bird™ fans with AC or EC motor depending on options.
- Carrier flooded shell-and-tube evaporator with new copper tubes for low pressure drops
- 3rd generation of “W” profile Carrier Novation™ microchannel heat exchangers with optional Enviro-Shield coatings.
- Carrier SmartView control with color touch screen user interface that includes 10 languages and new smart energy monitoring function.



CARRIER participates in the ECP programme for LCP/HP
Check ongoing validity of certifi
www.eurovent-certifi

AQUAFORCE[®], THE RIGHT SOLUTION FOR EVERY APPLICATION

Carrier's AquaForce[®] 30KAV range is available in three levels of efficiency to perfectly match each customer application and meet the European Ecodesign directive requirements.

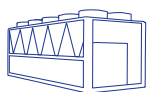
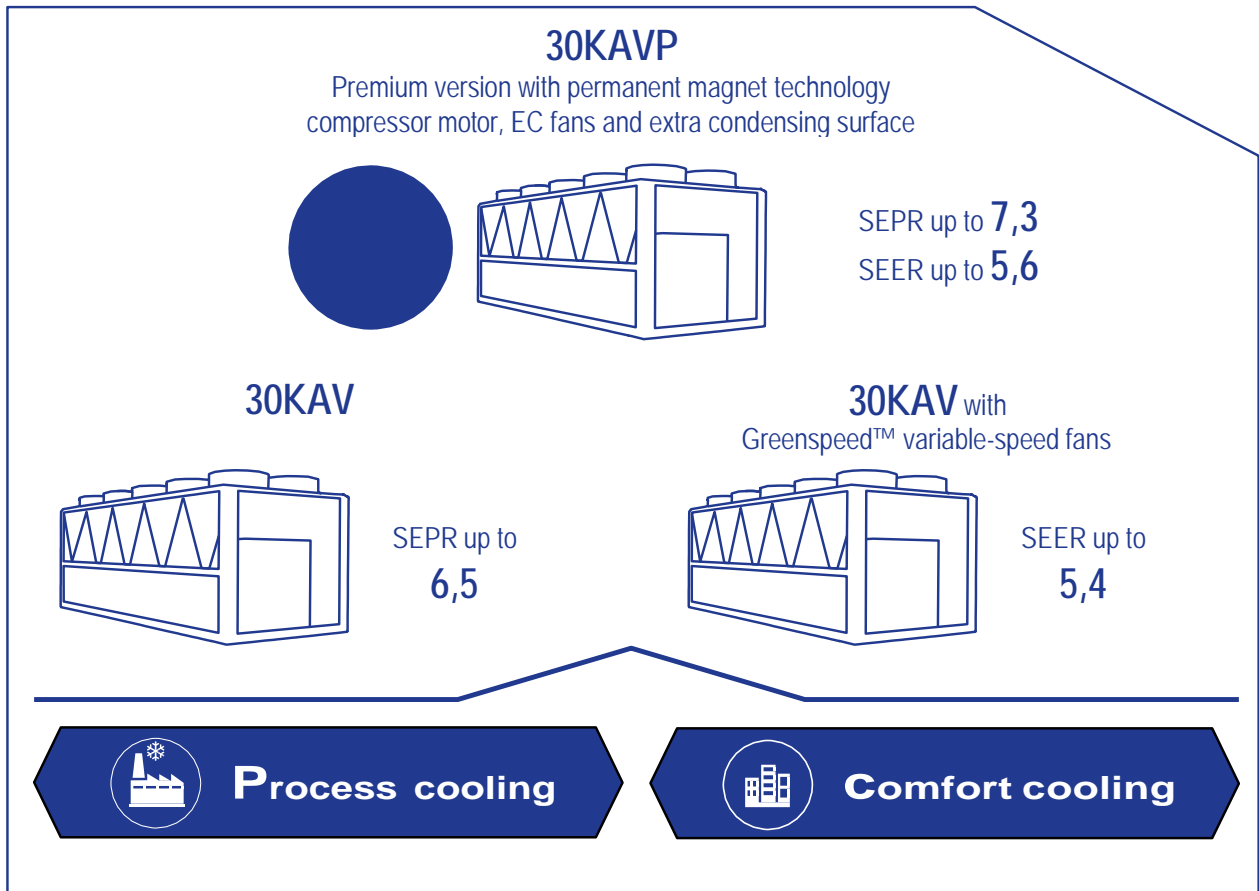

30KAV

The AquaForce[®] 30KAV is equipped with variable-speed screw compressor and fixed-speed fans with AC motor. The 30KAV offers an economical solution whilst providing high full load energy efficiency level for process applications and 12/7°C operation in hot climates. 30KAV is compliant with the 2018 EU Ecodesign SEPR -2/-8°C and 12/7°C requirements for medium and high temperature process chillers.

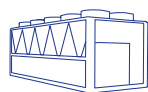

30KAV with Greenspeed™ intelligence

The AquaForce[®] 30KAV with Greenspeed™ intelligence is equipped with variable-speed AC fan motors. It offers an economical solution to enhance seasonal energy efficiency levels for comfort applications. The 30KAV with Greenspeed™ intelligence meets the 2018 EU Ecodesign SEER 12/7°C requirements.

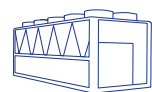

30KAVP

The AquaForce[®] 30KAVP with Greenspeed™ intelligence is the premium version with permanent magnet technology compressor motor, EC fans and additional heat exchange surface to improve both the full load and part load energy efficiency. The 30KAVP provides very cost effective operation in both process and comfort applications through the use of state of the art EC fan technology.

30KAV CUSTOMER BENEFITS

■ Outstanding performance

Equipped with variable-speed screw compressors and variable-speed fans (AC as standard and EC as option) and optional variable-speed pumps, Carrier's AquaForce® Vision 30KAV chiller with Greenspeed™ intelligence automatically adjusts the cooling capacity and the water flow to perfectly match the needs of the building or the process load variations. The result is optimum operation at both full load and part load (SEER up to 5.4). 30KAV offers energy efficiency up to 10% higher than the 30XAV range with the same footprint.

The range is already fully compliant with the 2021 Ecodesign regulations.



SEER
up to 5.4

■ Low sound levels

The new generation of Carrier 06Z variable-speed twin screw compressor with integrated resonator array and the 6th generation of Flying Bird™ fans with new fan blade design inspired by nature help reduce compressor and airflow noise down to as little as 90 dB(A). 30KAV is 6 dB(A) quieter than the previous AquaForce® 30XAV generation.



90 dB(A)

■ Intelligence and connectivity

The advanced SmartView intelligent control system displays operating parameters in real time, making it intuitive and particularly user-friendly. 30KAV also features innovative smart energy monitoring, providing users with smart data such as real time electric energy consumption, cooling energy output and instantaneous and average seasonal energy efficiency ratios. For further energy savings, 30KAV can be monitored remotely by Carrier experts for energy consumption diagnosis and optimization.



SMART ENERGY
MONITORING

■ Environmentally responsible

Carrier's AquaForce® Vision 30KAV is a boost for green cities and contributes to a sustainable future. Combining a reduced load refrigerant and exceptional energy efficiency it significantly lowers energy consumption while reducing carbon dioxide emissions by 25% throughout its life cycle.

The AquaForce® Vision version with PUREtec™ refrigerant designed exclusively for ultra low GWP HFO R-1234ze will be available during the course of 2019.



UP TO
25% LESS
CO₂ EMISSION

■ Extensive scope of application

Carrier's AquaForce® Vision adapts effortlessly to a wide range of applications. Extended operating temperatures from -20°C to 55°C outdoor air temperatures and negative water temperatures make it ideal for various sectors of activity. From high-end office buildings and hotels to healthcare facilities, data centers and industrial projects, AquaForce® Vision 30KAV meets the most demanding expectations in terms of energy efficiency and savings, whatever the climate and wherever the location.



FROM
-20°C
to 55°C

■ Easy installation & maintenance

Built-in variable-speed pumps up to 800 kW, automatic nominal water flow adjustment through electronic control, automatic unit energy performance measurement under real conditions, in units that are 25% smaller than the previous 30XAV generation, all these new features provide peace of mind for installers and service companies alike.

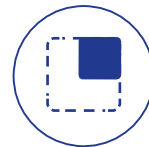

25%
SMALLER

30KAVP CUSTOMER BENEFITS

■ Outstanding performance

Equipped with variable-speed screw compressors with permanent magnet motor, EC fans and extra condensing surface, Carrier's AquaForce® Vision 30KAVP chiller with Greenspeed™ intelligence automatically adjusts the cooling capacity and the water flow to perfectly match the needs of the building or the process load variations.

The SEER is 25% above 2021 Ecodesign requirements.



SEER
up to 5.6

■ Low sound levels

The new generation of Carrier 06Z variable-speed twin screw compressor with integrated resonator array and the 6th generation of Flying Bird™ fans with new fan blade design inspired by nature help reduce compressor and airflow noise down to as little as 90 dB(A). 30KAVP is 6 dB(A) quieter than the previous AquaForce® 30XAV generation.



90 dB(A)

■ Intelligence and connectivity

The advanced SmartView intelligent control system displays operating parameters in real time, making it intuitive and particularly user-friendly. 30KAVP also features innovative smart energy monitoring, providing users with smart data such as real time electric energy consumption, cooling energy output and instantaneous and average seasonal energy efficiency ratios. For further energy savings, 30KAVP can be monitored remotely by Carrier experts for energy consumption diagnosis and optimization.



SMART ENERGY
MONITORING

■ Environmentally responsible

Carrier's AquaForce® Vision 30KAVP is a boost for green cities and contributes to a sustainable future. Combining a reduced load refrigerant and exceptional energy efficiency it significantly lowers energy consumption while reducing carbon dioxide emissions by 25% throughout its life cycle.

The AquaForce® Vision version with PUREtec™ refrigerant designed exclusively for ultra low GWP HFO R-1234ze will be available during the course of 2019.



UP TO
25% LESS
CO₂ EMISSION

■ Extensive scope of application

Carrier's AquaForce® Vision adapts effortlessly to a wide range of applications. Extended operating temperatures from -20°C to 55°C outdoor air temperatures and negative water temperatures make it ideal for various sectors of activity. From high-end office buildings and hotels to healthcare facilities, data centers and industrial projects, AquaForce® Vision 30KAVP meets the most demanding expectations in terms of energy efficiency and savings, whatever the climate and wherever the location.



FROM
-20°C
to 55°C

■ Easy installation & maintenance

Built-in variable-speed pumps up to 800 kW, automatic nominal water flow adjustment through electronic control, automatic unit energy performance measurement under real conditions, in units that are 25% smaller than the previous 30XAV generation, all these new features provide peace of mind for installers and service companies alike.

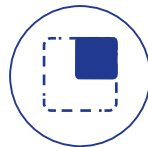

25%
SMALLER

CUSTOMER BENEFITS

AquaForce™ Vision 30KAV/30KAVP liquid chillers with Greenspeed™ Intelligence adapt effortlessly to a wide range of applications. An extended operating range covering ambient temperatures from -20 to 55°C makes it ideal for all areas of activity. From high-end offi buildings and hotels to healthcare facilities, data centers and industrial projects, 30KAV/30KAVP meets the most demanding expectations in terms of energy efficiency and savings, whatever the climate and wherever the location.

Furthermore, the advanced SmartView intelligent control system displays operating parameters in real time, making it intuitive and particularly user-friendly. 30KAV/30KAVP also features innovative smart energy monitoring, providing users with smart data such as real time electric energy consumption, cooling capacity, and instantaneous and average seasonal energy efficiency ratios as well as smart refrigerant leak alert that can indicate significant loss of refrigerant at any point of the system.

For further energy savings, 30KAV can be monitored remotely by Carrier experts for energy consumption diagnosis and optimization.

The 30KAV/30KAVP range is available in 5 efficiency levels.

■ 30KAV standard unit

The AquaForce™ 30KAV is equipped with variable-speed screw compressor and variable-speed fans with AC motors. The 30KAV is optimised to meet the most demanding technical and economic requirements while offering high seasonal energy efficiency levels.

(Average SEER of 5.17, average EER of 3.0)

■ 30KAV with EC fans (option 17)

The 30KAV with EC fans option enhances the seasonal energy efficiency and offers state of the art EC fan technology as standard.

(Average SEER of 5.23, average EER of 3.0)

■ 30KAV with High Energy Efficiency (option 119)

The 30KAV with High Energy Efficiency option is equipped with variable-speed fans with AC motor and additional heat exchange surface to deliver optimum performance at both full load and part load.

(Average SEER of 5.35, average EER of 3.4)

■ 30KAV with High Energy Efficiency+ (option 119+)

The 30KAV with High Energy Efficiency+ option is equipped with EC fans and additional heat exchange surface to provide the highest possible seasonal energy efficiency.

(Average SEER of 5.45, average EER of 3.4)

■ 30KAVP Premium Energy Efficiency.

The 30KAVP is based on 30KAV with option 119+. In addition, variable speed screw compressor is equipped with a premium permanent magnet motor. This is a synchronous motor without any slip and rotor losses.

(Average SEER of 5.6, average EER of 3.5)

SEER of the 30KAV/30KAVP range

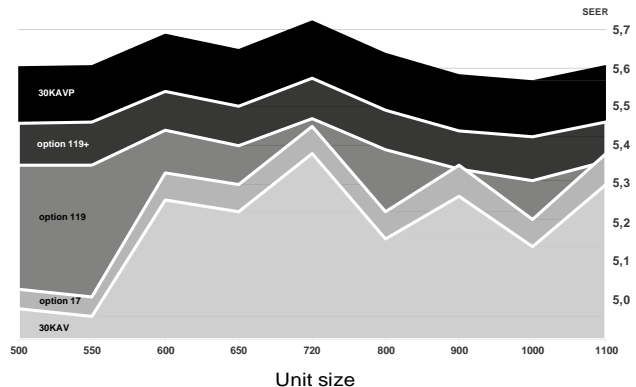

Outstanding energy performance

- The 30KAV with “High energy efficiency+” is designed for very high performance both at full and part load: average SEER 5.45, average EER 3.4 as per EN14825 & EN14511.
- The 30KAVP with “Premium energy efficiency” is designed for very high performance both at full and part load: average SEER 5.6, average EER 3.5 as per EN14825 & EN14511.
- The high energy efficiency is achieved through:
 - 2nd generation of Carrier high-efficiency variable-speed twin-screw compressors with built in volume index control (Vi) valve for both optimal full and part load performance
 - Variable-speed Flying Bird™ fans with EC motor minimising power consumption while delivering optimum air flow
 - Novation™ aluminum condenser with high-efficiency micro-channel coils technology
 - New Carrier flooded shell-and-tube evaporator with new copper tubes for low pressure drops
 - Electronic expansion device permitting operation at a lower condensing pressure and improved utilisation of the evaporator heat exchange surface (superheat control)
 - Economiser system with electronic expansion device for increased cooling capacity.
- Optimised electrical performance:
 - Negligible start-up current (value is lower than the maximum unit current draw)
 - High displacement power factor (above 0.98)
 - EMC compliance with Class 3 requirements of the EU standard EN61800-3 (Class 2 is possible as an option).
- Hydraulic module with variable-speed dual pump
 - Variable-speed, dual pumps which automatically adjust the water fl to match the needs of the building or process load variations.
 - 3 pump control modes available: constant water flow with possibility to reduce the pump speed when there is no cooling demand, variable water flow with constant delta T or constant delta P control.
- Smart energy monitoring
 - Innovative smart energy monitoring providing users with smart data such as real time electric energy consumption, cooling cooling capacity, and instantaneous and average seasonal energy efficiency ratios (Electricity metering accuracy: +/-5%. Cooling capacity metering accuracy: +/-5% at nominal rated conditions).
 - For further energy savings, 30KAV can be monitored remotely by Carrier experts for energy consumption diagnosis and optimization.

CUSTOMER BENEFITS

Built-in reliability and easy servicing

The 30KAV/30KAVP units offer enhanced performances as well as Carrier's acclaimed product quality and reliability. Major components were chosen, selected and tested to minimise the possibility of failure.

- 2nd generation of variable-speed twin-screw compressors:
 - The screw compressors are industrial-type with oversized bearings and motor cooled by suction gas, with a proven failure rate lower than 0.1%.
 - 30KAVP is fitted with a Permanent Magnet (PM) motor to run the variable screw compressor.
 - Motor is synchronous and spins at supplied frequency, without any slip and rotor losses to induce magnetic field. There is a benefit of +1% in full load efficiency and of +4% in part load efficiency compared to induction motors.
 - Air-cooled compressor variable-speed drive (VSD) to ensure reliable operation and easy maintenance. (Glycol-cooled variable-speed drive (VSD) types are subject to higher failure rates due to glycol pump issue. Refrigerant-cooled variable-speed drive (VSD) types are subject to higher compressor vibration levels causing possible failures in the long term).
 - Compressor bearing life exceeding 100 000 hours
 - All components related to the compressor assembly are easily accessible on site minimising down-time.

- Variable-speed fans:

30KAV is fitted with variable-speed asynchronous fan-motors as standard. One variable-speed drive (VSD) is sized to manage a group of fans per refrigerant circuit reducing first cost while ensuring high part-load efficiency.

30KAV with High Energy Efficiency+ option and 30KAVP is fitted with variable-speed EC fan-motors. Each EC fan is controlled independently ensuring continuous chiller operation in case of motor or drive failure.

- Air-cooled condenser:
 - NovationTM aluminum micro-channel heat exchanger (MCHE) with high corrosion resistance. The all aluminum design eliminates the formation of galvanic currents between aluminum and copper that cause coil corrosion in saline or corrosive environments.
 - Enviro-shieldTM coating for MCHE used in standard and mildly corrosive environments with superior durability confirmed through 5000 hours testing in constant neutral salt spray per ASTM B117 and superior heat transfer performances confirmed through 2000 hours testing per CM1 (Carrier proprietary testing).
 - Super Enviro-shieldTM coating for MCHE used in highly corrosive environments (industry or marine applications) with superior durability confirmed through 5000 hours testing in constant neutral salt spray per ASTM B117 and superior heat transfer performances confirmed through 2000 hours testing per CM1 (Carrier proprietary testing).
- Evaporator:
 - Carrier designed flooded evaporator with mechanically cleanable water tubes
 - Electronic paddle-free flow switch to ensure prompt alarm in case of poor liquid flow rate
 - Thermal insulation with aluminum sheet finish (option) improved resistance to mechanical and UV damage.
- Refrigerant circuits:
 - Two independent refrigerant circuits to secure partial cooling, if one of the two develops a fault.
- Auto-adaptive control:
 - Control algorithm prevents excessive compressor cycling (Carrier patent)

- Automatic compressor unloading in case of abnormally high condensing pressure. If condenser coil fouling or fan failure occurs, the Aquaforce continues to operate, but at reduced capacity.

- Exceptional endurance tests:

- To design critical components and sub-assemblies to minimise the risk of failure on site, Carrier uses specialised laboratories and advanced dynamic simulation tools.
- To ensure that the units reach customer sites in the same condition as they are when tested in the factory, Carrier tests the machine behavior while being moved along a 250 km trial. The test-route is based on a military standard and is the equivalent to 5000km by truck in a normal road.
- To ensure coils corrosion resistance, salt mist corrosion resistance test are performed in UTC's laboratory.

In addition, to maintain unit performance throughout its operating life, whilst minimising maintenance costs, end users can access the "Carrier Connect" remote monitoring service.

Minimised operating sound levels

- The Greenspeed[®] Intelligence, featuring variable-speed screw compressors and condenser fans, minimises noise levels at part load operation.

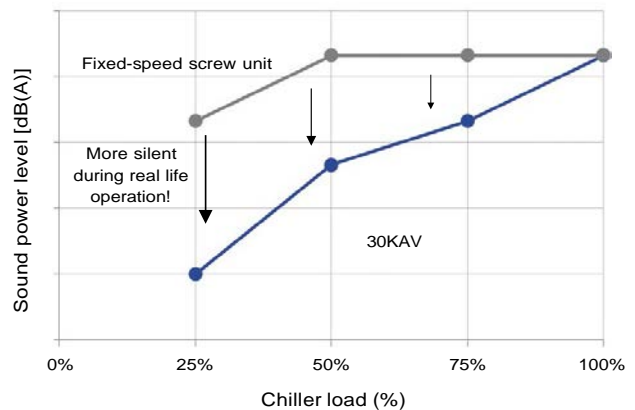

- Standard unit features include:

- The new generation of Carrier 06Z variable-speed twin screw compressor with integrated resonator array to reduce the noise level by 6 dB(A) compared with 06T twin screw compressor previous generation.
- The 6th generation of silent Flying BirdTM fans with new fan blade design inspired by nature, help reduce airflow noise.

- 30KAV/30KAVP is available with 4 sound levels to match the most sensitive environments:

- Standard: standard unit configuration with new generation of low sound screw compressor and fans
- Low noise option: addition of high-performance compressor sound enclosure
- Very low noise option: addition of high-performance compressor sound enclosure and fan operation at lower rotational speed.

Easy and fast installation

- Built-in variable speed pumps up to 800 kW
 - Full hydraulic module with dual pumps (low or high pressure as required) and optional expansion tank
 - Automatic nominal water flow adjustment through electronic control on the user display
- Compact units for easy transportation and installation.
 - Dimensions 25% smaller than the previous 30XAV generation

CUSTOMER BENEFITS

- Similar dimensions as the old 30GX chillers for easy replacement of the installed base.
- Simplified electrical connections:
 - Main disconnect switch
 - Transformer supply to the integrated control circuit (400/24V)
 - Single electrical point of connection
- Simplified water connections:
 - Victaulic connections on the evaporator
 - Clearly identified entering and practical reference marks for entering and leaving water connections
 - Possibility to choose different evaporator configurations, 1 or 2 passes.
- Fast commissioning:
 - Systematic factory operating test before shipment
 - Functional test for main components, expansion devices, fans and compressors.

Environmental care

- The AquaForce™ Vision 30KAV/30KAVP liquid chillers with Greenspeed™ Intelligence is a boost for green cities and contributes to a sustainable future. Combining a reduced charge of R134a refrigerant and exceptional energy efficiency it significantly lowers energy consumption while reducing carbon dioxide emissions by 25% throughout its life cycle (compared to previous fixed-speed screw liquid chiller generation).
- The AquaForce™ Vision 30KAV/30KAVP liquid chiller is equipped with an automatic energy meter that provides estimated instantaneous and cumulative cooling energy output, instantaneous and cumulative electric energy consumption, instantaneous and average seasonal energy efficiency ratios (Accuracy: +/- 5% at nominal condition, +/-10% elsewhere) for unit performance monitoring and verification.
- The AquaForce™ Vision 30KAVZE version with PUREtec™ refrigerant designed exclusively for HFO R-1234ze will be available during the course of 2019.
- R-134a: HFC refrigerant with zero ozone depletion potential
- 40% less refrigerant charge: The micro-channel technology used for condenser coils optimises heat transfer while minimising the refrigerant volume.
- Leak tight refrigerant circuits:
 - Reduction of leaks as no capillary tubes and flare connections are used
 - Verification of pressure transducers and temperature sensors without transferring refrigerant charge
 - Discharge line shut-off valve and liquid line service valve for simplified maintenance.
- Refrigerant leak alert: The AquaForce™ Vision 30KAV/30KAVP liquid chiller is equipped with an automatic refrigerant leak detection algorithm that can detect serious refrigerant loss at any point on the system (Sensitivity: 25% refrigerant charge loss per circuit, depending on the conditions). The automatic refrigerant leak detection system can help to achieve recognition within pollution prevention assessment programs, ideal for assisting in the design of sustainable buildings.
- Refrigerant leak detection: Available as an option, this additional dry-contact allows reporting of possible leaks. The leak detector (by others) should be mounted in the most likely leak location.

Designed to support Green Building Design

A green building is a building that is environmentally sustainable and has been designed, constructed and is operated to minimise the total impact on the environment.

The resulting building will be economical to operate, offer increased comfort and create a healthier environment for the people who live and work there, increasing productivity.

The air conditioning system can use between 30 and 40% of the annual building energy consumption. Selection of the right air conditioning system is one of the main aspects to consider when designing a green building. For buildings with a variable load throughout the year 30KAV/30KAVP units offer a solution to this important challenge.

A number of green building certification programs exist in the market and offer third-party assessment of green building measures for a wide variety of building types.

The following example looks at how Carrier's new 30KAV/30KAVP range helps customers involved in LEED® building certification.

Energy saving certificate

30KAV-30KAVP is eligible to Energy savings certificates in France (CEE) in comfort, industrial and agriculture applications:

- Floating High pressure control (by modulating the air flow through fan activation and its speed)
- Floating Low pressure control
- Variable speed on asynchronous compressor motor
- Variable speed on asynchronous fan motor
- Variable speed on asynchronous pump motor

30 KAVP with its PM Motor is also eligible to:

- Variable speed on synchronous compressor motor

For more details about financial incentives in France, please refer to "Fiche produit CEE"

30KAV and LEED® certification

The LEED® (Leadership in Energy and Environmental Design) green building certification programme is a preeminent programme to rate the design, construction and operation of green buildings with points assigned in seven credit categories:

- Sustainable Sites (SS)
- Water Efficiency (WE)
- Energy & Atmosphere (EA)
- Materials & Resources (MR)
- Indoor Environmental Quality (IEQ)
- Innovation in Design (ID)
- Regional Priority (RP).

There are a number of different LEED® products.

While the strategies and categories assessed remain same, the point distribution varies to address different building types and application needs, for example according to New Construction, Schools, Core & Shell, Retail and Healthcare.

All programmes now use the same point scale:

110 Possible LEED® points

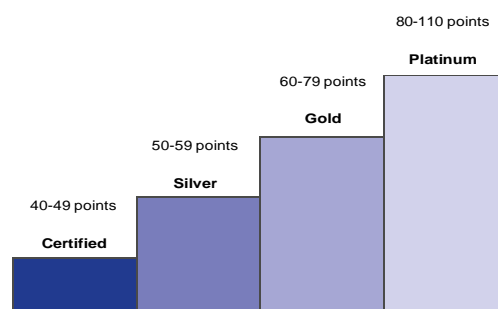

CUSTOMER BENEFITS

The majority of credits in LEED® rating systems are performance-based and achieving them is dependent on the impacts of each component or sub-system to the overall building.

While the LEED® green building certification programs do not certify products or services, the selection of the right products, systems or service programs is critical to obtain LEED® certification for a registered project, because the right products or service programmes can help meet the goals of green construction and ongoing operation and maintenance.

The choice of heating, ventilating and air conditioning (HVAC) products in particular can have a significant impact on LEED® certification, as the HVAC system directly impacts two categories that together influence 40% of the available points

Overview of LEED® for new construction and major renovations

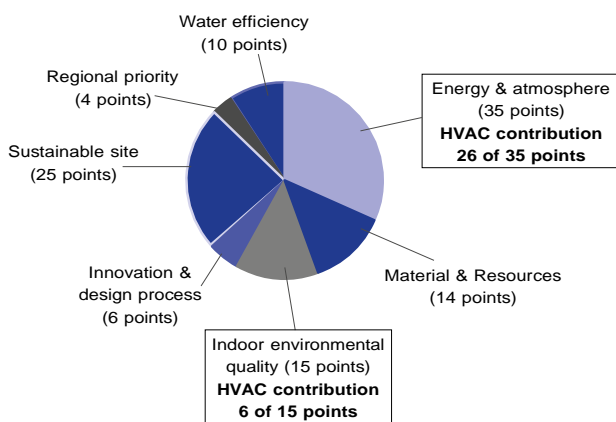

The new 30KAV/30KAVP units from Carrier can assist building owners to earn LEED® points in particular in the Energy & Atmosphere (EA) credit category and help address the following prerequisites and credit requirements:

- **EA prerequisite 2: Minimum energy Performance**
The 30KAV/30KAVP exceeds the energy efficiency requirements of ASHRAE 90,1-2007; therefore it complies with the prerequisite standard.
- **EA prerequisite 3: Fundamental Refrigerant Management**
The 30KAV/30KAVP does not use chlorofl (CFC) refrigerants thus satisfying the prerequisite statement.
- **EA credit 1: Optimise energy performance (1 to 19 points):**
Points for this credit are assigned depending on the energy cost reduction virtually achievable by the new building, compared to ASHRAE 90,1-2007 reference. The 30KAV/30KAVP, which is designed for high performance especially during part load operation, contributes to reducing the energy consumption of the building and therefore helps in gaining points within this credit. In addition, the Carrier HAP (Hourly Analyses Program) can be used as an energy analyses program complying with the modeling requirements for this credit and produce reports that are easily transferable to LEED® templates.
- **EA credit 4: Enhanced refrigerant management (2 points):**
With this credit, LEED® awards systems that minimise the Ozone Depletion Potential (ODP) and Global Warming Potential (GWP) of the system. The 30KAV/30KAVP uses a reduced R134a charge and therefore contributes toward satisfying this credit under LEED®.

NOTE: This section describes the prerequisites and credit requirements in LEED® for New Construction and is directly related to the 30KAV/30KAVP. Other prerequisites and credit requirements are not directly and purely related to the air-conditioning unit itself, but more to the control of the complete HVAC system.

i-Vu®, Carrier's open control system, has features that can be valuable for:

- EA prerequisite 1: Fundamental commissioning of energy management system
- EA credit 3: Enhanced commissioning (2 points)
- EA credit 5: Measurements and verification (3 points).

NOTE: Products are not reviewed or certified under LEED®. LEED® credit requirements cover the performance of materials in aggregate, not the performance of individual products or brands. For more information on LEED®, visit www.usgbc.org.

30KAV TECHNICAL INSIGHTS

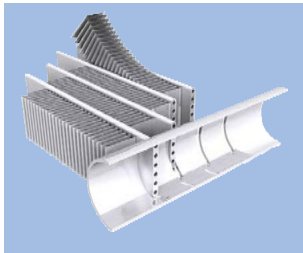

U SHAPE NOVIATION®

MICRO CHANNEL HEAT EXCHANGERS

- Exclusive Carrier design
- Increased reliability with new aluminum alloy
- Significantly reduces refrigerant charge (-40% vs cu/al coils)
- More compact units (-25% vs previous 30XAV generation)
- Enviro-shield™ coating for mildly corrosive environments
- Super Enviro-shield™ coating for highly corrosive environments (industry or marine applications)
- Easy cleaning with high pressure air or water washer

ADVANCED SMARTVIEW WITH 7 INCH COLOR TOUCH SCREEN INTERFACE

- Exclusive Carrier design
- 10 languages available: DE, EN, ES, FR, IT, NL, PT, TR, TU + one additional customer choice
- Touch screen user interface
- BACnet, J-Bus or LON communication interfaces
- Optional wireless connectivity



POWERFUL SMART ENERGY MONITORING FUNCTION

- Provides smart data based on intelligent algorithms
- Real time energy consumption measurement (kWh)
- Cooling energy output measurement (kWh)
- Instantaneous and average Energy Efficiency Ratio under real operating conditions
- Remote monitoring with Carrier Connect

FLOODED SHELL AND TUBE EVAPORATOR

- Exclusive Carrier design
- Flooded technology for high energy efficiency
- New generation of copper tubes with specific profile to reduce pressure drops when operating with glycol



6TH GENERATION OF VARIABLE-SPEED FLYING BIRD™ FANS WITH AC OR EC MOTOR

- Exclusive Carrier design
- Fan blade design inspired by nature
- High efficiency version with AC motor technology
- EC motor technology (option)



VARIABLE-SPEED DUAL PUMPS WITH AC MOTOR

- Dual pumps designed for variable speed operation
- High efficiency AC motor
- Low static pressure (~100 kPa) or high static pressure (~180 Kpa) available
- 3 pump control modes available: constant water flow with 2 speeds, variable water fl based on constant delta T or constant delta P
- Compatibility of chillers for variable primary flow operation

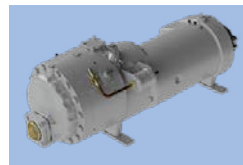

LATEST GENERATION CARRIER VARIABLE-SPEED 06Z TWIN SCREW COMPRESSOR WITH AC MOTOR

- Exclusive Carrier design
- Twin screw compressor designed for variable speed operation
- High efficiency AC motor
- Stepless variable-speed control (0%-100%)
- Integrated resonator array for compressor acoustic attenuation
- Integrated check valve for quiet shutdown
- Air-cooled inverter drive for increased reliability
- Bearing life exceeding 100.000 hours
- Twin screw compressor with permanent magnet motor as option

VARIABLE-SPEED FLYING BIRD™ FANS WITH EC MOTOR

- Exclusive Carrier design

6TH GENERATION OF

TECHNICAL INSIGHTS

SmartView



- New innovative smart control features:
 - An intuitive and user-friendly, coloured, 7" interface
 - 10 languages available on choice: DE, EN, ES, FR, IT, NL, PT, TR, TU + one additional customer choice
 - Screen-shots with concise and clear information in local languages
 - Complete menu, customised for different users (end user, service personnel and Carrier-factory technicians)
 - Setpoint offset based on the outside air temperature
 - Safe operation and unit setting: Password protection ensures that unauthorised people cannot modify any advanced parameters
 - Simple and "smart" intelligence uses data collection from the constant monitoring of all machine parameters to optimise unit operation
 - Night-mode: Cooling capacity management for reduced noise level.
 - With hydraulic module: Water pressure display and water flow rate calculation.
- Energy management:
 - Innovative smart energy monitoring, providing users with smart data such as real time electric energy consumption, cooling capacity, and instantaneous and average seasonal energy efficiency ratios.
 - Internal time schedule clock controls chiller on/off times and operation at a second set-point
 - The DCT (Data Collection Tool) records the alarms history to simplify and facilitate service operations.
- Maintenance functions
 - F-Gas regulation leak check reminder alert
 - Maintenance alert can be configured to days, months or hours of operation
- Advanced communication features
 - Easy and high-speed communication technology over Ethernet (IP) to a centralised building management system
 - Access to multiple unit parameters.

Remote management (standard)

- Units with SmartView control can be easily accessed from the internet, using a PC with an Ethernet connection. This makes remote control quick and easy and offers significant advantages for service operations.
- Aquaforce with Greenspeed® Intelligence is equipped with an RS485 serial port that offers multiple remote control, monitoring and diagnostic possibilities. When networked with other Carrier equipment through the CCN (Carrier Comfort Network - proprietary protocol), all components form a HVAC system fully-integrated and balanced through one of the Carrier's network system products, like the Chiller System Manager or the Plant System Manager (optional).

- The 30KAV/30KAVP also communicates with other building management systems via optional communication gateways (BACnet, LON or JBus).
- The following commands/visualisations are possible from remote connection:
 - Start/Stop of the machine
 - Dual set-point management: Through a dedicated contact is possible to activate a second set-point (example, unoccupied mode)
 - Demand limit setting: To limit the maximum chiller capacity to a predefined value
 - Water pump control: These outputs control the contactors of one/two evaporator water pumps.
 - Water pumps changeover (only with hydraulic module options): These contacts are used to detect a water pump operation fault and automatically change over to the other pump.
 - Operation visualisation: Indication if the unit is operating or if it is in stand-by (no cooling load)
 - Alarm visualisation.

Remote management (EMM option)

- The Energy Management Module (EMM) offers extended remote control possibilities:
 - Room temperature: Permits set-point reset based on the building indoor air temperature (if Carrier thermostats are installed)
 - Set-point reset: Allows reset of the cooling set-point based on a 4-20 mA or 0-10 V signal
 - Demand limit: Permits limitation of the maximum chiller capacity based on 0-10 V signal
 - Demand limit 1 and 2: Closing of these contacts limits the maximum chiller capacity to two predefined values.
 - User safety: This contact can be used for any customer safety loop; opening the contact generates a specific alarm.
 - Ice storage end: When ice storage has finished, this input permits return to the second set-point (unoccupied mode).
 - Time schedule override: Closing of this contact cancels the programmed time schedule.
 - Out of service: This signal indicates that the chiller is completely out of service.
 - Chiller capacity: This analogue output (0-10 V) gives an immediate indication of the chiller capacity.
 - Alert indication: This volt-free contact indicates the necessity to carry out a maintenance operation or the presence of a minor fault.
 - Compressors running status: Set of outputs (as many as the compressors number) indicating which compressors are running.

TECHNICAL INSIGHTS

New generation of Carrier 06Z variable-speed twin screw compressor



The new generation of 06Z variable-speed twin screw compressors benefits from Carrier's long experience in the development of twin-rotor screw compressors. The 06Z compressor design is based on the successful 06T screw compressor, core of the well-known Aquaforce series with a number of modifications to reduce noise level and improve the energy efficiency especially during part load operation.

- New 06Z twin screw compressor optimized for variable speed operation: elimination of the slide valve, built-in volume index control (Vi) valve for both optimal full and part load performance, high efficiency AC motor with stepless inverter control from 20% to 100%.
- 30KAVP screw compressor is equipped with a Permanent Magnet (PM) Motor, which is a four pole motor compared to the two pole induction motor. By the way, the frequency setting doubles with PM motors, but the shaft speed remains the same. There is no slip or rotor losses. Thus, there is a benefit of +1% in full load efficiency and of +4% in part load efficiency.

Permanent Magnet Motor



- Separate air-cooled inverter drive for increased reliability
- New 06Z twin screw compressor design with Integrated Resonator Array (IRA) to reduce the sound level by up to 6 dB(A) when compared with previous 06T generation
- Integrated Check Valve for quiet shutdown
- Bearing life exceeding 100 000 hours.
- A dedicated oil separator is installed at the discharge of each compressor to ensure maximum oil return: Oil separates from refrigerant by gravity and returns to the low pressure side of the compressor without use of additional pumps.
- Volume index control (Vi) valve provides a reliable method of adjusting the compression ratio to better match system demand. It provides optimal performance regardless of operating condition
- Screw compressors work on the positive displacement principle to compress gas to a higher pressure. As a result, if there is an unusually high pressure in the condenser (due for example to coil fouling or operation in harsh climate) the compressor does not switch off, but continues operation at reduced capacity (unloaded mode).
- The silencer in the oil separator line (at the compressor outlet) considerably reduces discharge gas pulsations for much quieter operation.

TECHNICAL INSIGHTS

Novation[®] Heat Exchangers with Microchannel Coil Technology

Already utilised in the automobile and aeronautical industries for many years, the Novation[™] Micro-Channel Heat Exchanger (MCHE) used in the Aquaforce is entirely made of aluminum. This one-piece concept significantly increases its corrosion resistance by eliminating the galvanic currents that are created when two different metals (copper and aluminum) come into contact in traditional heat exchangers.

- From the energy efficiency point-of-view the Novation[®] heat exchangers are approximately 10% more efficient than traditional coils and micro-channel coil technology allows a 40% reduction in the amount of refrigerant used in the chiller.
- The reduced depth of the Novation[™] MCHE reduces air pressure losses by 50% and makes it much less susceptible to fouling (e.g. by sand). Cleaning of the Novation[™] MCHE heat exchanger is very fast using a high pressure washer.
- To further enhance long-term performance, and protect coils from early deterioration, Carrier offers (as options) dedicated treatments for installations in corrosive environments.
 - The Novation[™] MCHE with Enviro-Shield protection (option 262) is recommended for installations in moderately corrosive environments. The Enviro-Shield protection utilises corrosion inhibitors which actively arrest oxidation in case of mechanical damage.
 - The Novation[™] MCHE with exclusive Super Enviro-Shield protection (option 263) is recommended for installations in corrosive environments. The Super Enviro-Shield protection consist of an extremely durable and flexible epoxy coating uniformly applied over all coil surfaces for complete isolation from the contaminated environment.
- After a total of more than 7,000 hours of testing following various test standards in UTC laboratories, the Carrier Novation[®] MCHE with Super Enviro-shield[®] coating appears to be the best-suited customer choice to minimize the harmful effects of corrosive atmospheres and ensure long equipment life.
 - Best corrosion resistance per ASTM B117/D610 test
 - Best heat transfer performance per Carrier Marine 1 test
 - Proven reliability per ASTM B117 test

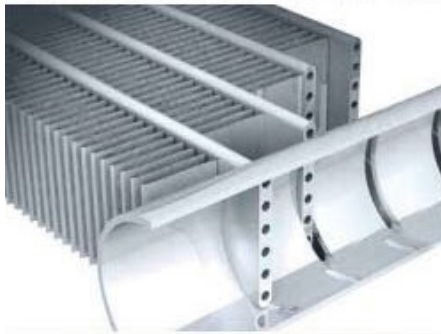

Coil Types (ranked by performance)	Visual Corrosion Evaluation	Heat Transfer Performance Degradation	Time to Failure	Test Campaign Conclusions
Super Enviro-shield [®] Novation [™] MCHE	Very good	Good	No coil leak	Best
Super Enviro-shield [®] Cu/Al coil	Very good	Very good	No coil leak	Very good
Enviro-shield [®] Novation [™] MCHE	Very good	Good	No coil leak	Very good
Al/Al coil	Very good	Good	No coil leak	Very good
Novation [™] MCHE	Good	Very good	No coil leak	Good
Cu/Cu coil	Good	Good	Leak	Acceptable
Blygold [®] Cu/Al coil	Good	Good	No coil leak	Acceptable
Precoat Cu/Al coil	Bad	Bad	No coil leak	Bad
Cu/Al coil	Bad	Bad	No coil leak	Bad

TECHNICAL INSIGHTS

New generation of Flying Bird VI fans with EC motors



The 30KAV/30KAVP utilizes Carrier's the 6th generation Flying Bird™ fan technology, engineered for maximum efficiency, super low noise, and wide operating range. The fan includes Carrier patented rotating shroud technology and back-swept blades with a unique wave-serration trailing edge inspired from nature.

It was designed and optimized for the 30KAV/30KAVP air management system configuration and heat exchanger technology. On 30KAVP, and on 30KAV with option 17 and option 119+, fans are propelled by an EC motor, also known as brushless DC, with a unique electronics to manage commutation. This provides a great accuracy for fans that require higher efficiencies and variable speed. The fan meets the latest European eco-design requirements for fan efficiency. The fan uses Carrier's robust and proven injection molded composite-thermoplastic construction.

EC Motor



TECHNICAL INSIGHTS

Variable Frequency Drives (VFD)

The compressors, the fans and the pumps of 30KAV-30KAVP are controlled by VFDs.

- VFDs electrical box has an IP44 rating as standard and IP54 as an option (available in 2019).
- Electrical box is capable of operating up to 55°C (with option 16 "High Ambient").
- Unit controls is capable of withstanding storage temperatures in the control compartment from -20°C to 68°C.
- All VFDs on the chiller (compressors, fans and pumps motors) are fully air cooled and shall not require an additional glycol cooling system, thus avoiding the maintenance associated with such cooling systems.



Fan drives + Pump drives +
electronic boards



Compressor drives + main
power connection

OPTIONS

Option	No.	Description	Advantage	30KAV/P
Medium-temperature brine solution	5	Implementation of new control algorithms and redesigned evaporator to allow chilled brine solution production down to -8°C when ethylene glycol is used (-5°C with propylene glycol)	Covers specific applications such as ice storage and industrial processes	0500-1100
Low Brine with turbulators down to -15°C	6	Redesigned evaporator including turbulators to allow chilled brine solution production with low pressure drops on the entire negative application range, down to -15°C (including turbulators, extra insulation, specific sensors and algorithms).	Covers specific applications such as ice storage and industrial processes	0500-1100
Light-brine solution, down to -4°C	8	Implementation of new control algorithms and redesigned evaporator to allow chilled brine solution production down to -4°C when ethylene glycol is used (-2°C with propylene glycol)	Matches with most application requirements for ground-sourced heat pumps and fits with many industrial processes requirements	0500-1100
Low noise level	15	Aesthetic and sound absorbing compressor enclosure	Noise level reduction	0500-1100
Very low noise level	15LS	Sound absorbing & aesthetic compressor enclosure and oil separator, evaporator and suction line acoustic treatment, combined with low-speed fans	Noise level reduction in sensitive environments	0500-1100
High ambient temperature	16	Electrical components sized for part load operation up to 55°C air ambient	Extended unit part-load operation up to 55°C ambient temperature	0500-1100
EC fans	17	Unit equipped with EC fans	Enhances the unit energy efficiency	0500-1100 "already included on 30KAVP"
IP54 control box	20A	Increased leak tightness of the unit	Protects the inside of the electrical box from dust, water and sand. In general this option is recommended for installations in polluted environments	0500-1100
Grilles and enclosure panels	23	Metal grilles on the 4 unit sides, plus side enclosure panels at each end of each coil	Improves aesthetics, protection against intrusion to the unit interior, coil and piping protection against impacts.	0500-1100
Enclosure panels	23A	Side enclosure panels	Improves aesthetics and piping protection against impacts.	0500-1100
Water exchanger frost protection	41A	Electric resistance heater on the water exchanger and discharge valve	Water exchanger frost protection down to -20°C outside temperature	0500-1100
Evaporator & hydraulic module frost protection	41B	Electric resistance heater on water exchanger, discharge valve and hydraulic module	Water exchanger and hydraulic module frost protection down to -20°C outside temperature	0500-0800
Evaporator & condenser frost protection	41C	Electric resistance heater on evaporator exchanger, discharge valve and add heaters and insulation on hydraulic connection (option 325)	Water exchanger module frost protection between 0°C and -20°C outside air temperature	0500-1100
Partial heat recovery	49	Unit equipped with one desuperheater on each refrigerant circuit (Each exchanger is equipped with heaters and insulation)	Production of free high-temperature hot-water simultaneously with chilled water production (or hot water for Heat pump)	0500-1100
Total heat recovery	50	Unit equipped with additional heat exchanger in series with the condenser coils (Each exchanger is equipped with heaters and insulation)	Production of free hot-water with variable heat reclaim	0500-1100
Master/slave operation	58	Unit equipped with supplementary water outlet temperature sensor kit (to be field installed) allowing master/slave operation of two units connected in parallel	Optimised operation of two units connected in parallel operation with operating time equalisation	0500-1100
Main disconnect switch with short-circuit protection	70D	Circuit breaker equipped with an external disconnect switch handle	Ensure protection of main disconnect switch and associated cables against short-circuits when building devices are not compliant	0500-1100
Evap. and pumps with aluminum jacket	88A	Evaporator and pumps covered with an aluminum sheet for thermal insulation protection	Improved resistance to aggressive climate conditions	0500-1100
Service valve set	92	Liquid line valve (evaporator inlet) and compressor suction line valve	Allow isolation of various refrigerant circuit components for simplified service and maintenance	0500-1100
Compressor discharge valves	93A	Shut-off valve on the compressor discharge piping	Simplified maintenance	0500-1100
21 bar evaporator	104	Reinforced evaporator for extension of the maximum water-side service pressure to 21 bar (standard 10 bar)	Covers applications with a high water column evaporator side (typically high buildings)	0500-1100

OPTIONS

Option	No.	Description	Advantage	30KAV/P
LP VSD dual-pump hydraulic mod.	116A	Dual low-pressure water pump with variable speed drive (VSD), pressure transducers. Multiple possibilities of water flow control. For more details, refer to the dedicated chapter.	Easy and fast installation (plug & play), significant pumping energy cost savings (more than two-thirds), tighter water flow control, improved sytem reliability	0500-0800
HP VSD dual-pump hydraulic mod.	116W	Dual high-pressure water pump with variable speed drive (VSD), pressure transducers. Multiple possibilities of water flow control. For more details, refer to the dedicated chapter (expansion tank not included Option with built-in safety hydraulic components available)	Easy and fast installation (plug & play), significant pumping energy cost savings (more than two-thirds), tighter water flow control, improved sytem reliability	0500-0800
High Energy Efficiency	119	Additional condenser coil to improve unit energy efficiency	Enhances the unit energy efficiency performance	0500-1100 "already included on 30KAVP"
High Energy Efficiency+	119+	Additional condenser coil plus EC fans to improve unit energy efficiency	Enhances the unit energy efficiency performance	0500-1100 "already included on 30KAVP"
Lon gateway	148D	Bi-directional communication board complying with Lon Talk protocol	Connects the unit by communication bus to a building management system	0500-1100
Bacnet over IP	149	Bi-directional high-speed communication using BACnet protocol over Ethernet network (IP)	Easy and high-speed connection by ethernet line to a building management system. Allows access to multiple unit parameters	0500-1100
Modbus over IP and RS485 communication gateway	149B	Bi-directional high-speed communication using the Modbus over Ethernet network (IP) protocol	Easy, quick connection via Ethernet line to a building technical management system. Allows access to several unit parameters.	0500-1100
Energy Management Module	156	EMM Control board with additional inputs/outputs. See Energy Management Module option chapter	Extended remote control capabilities (Set-point reset, ice storage end, demand limits, boiler on/off command...)	0500-1100
Input contact for Refrigerant leak detection	159	0-10 V signal to report any refrigerant leakage in the unit directly on the controller (the leak detector itself must be supplied by the customer)	Immediate customer notification of refrigerant losses to the atmosphere, allowing timely corrective actions	0500-1100
Dual relief valves on 3-way valve	194	Three-way valve upstream of dual relief valves on the shell and tubes evaporator	Valve replacement and inspection facilitated without refrigerant loss. Conforms to European standard EN378/BGVD4	0500-1100
Compliance with Swiss regulations	197	Additional tests on the water heat exchangers: supply (additional of PED documents) supplementary certificates and test certifications	Conformance with Swiss regulations	0500-1100
Compliance with Russian regulations	199	EAC certification	Conformance with Russian regulations	0500-1100
Compliance with Australian regulations	200	Unit approved to Australian code	Conformance with Australian regulations	0500-1100
Insulation of the evap. in/ out ref.lines	256	Thermal insulation of the evaporator entering/leaving refrigerant lines with flexible, UV resistant insulation	Prevents condensation on the evaporator entering/leaving refrigerant lines	0500-1100
Enviro-Shield anti-corrosion protection	262	Coating by conversion process which modifies the surface of the aluminum producing a coating that is integral to the coil. Complete immersion in a bath to ensure 100% coverage. No heat transfer variation, tested 4000 hours salt spray per ASTM B117	Improved corrosion resistance, recommended for use in moderately corrosive environments	0500-1100
Super Enviro-Shield anti-corrosion protection	263	Extremely durable and flexible epoxy polymer coating applied on micro channel heat exchangers by electro coating process, final UV protective topcoat. Minimal heat transfer variation, tested 6000 hours constant neutral salt spray per ASTM B117, superior impact resistance per ASTM D2794	Improved corrosion resistance, recommended for use in extremely corrosive environments	0500-1100
Welded evaporator connection kit	266	Victaulic piping connections with welded joints	Easy installation	0500-1100
Welded heat recovery condenser connection kit	267	Victaulic piping connection with welded joints	Easy installation	0500-1100

OPTIONS

Option	No.	Description	Advantage	30KAV/P
Evaporator with aluminum jacket	281	Evaporator covered with an aluminum sheet for thermal insulation protection	Improved resistance to aggressive climate conditions	0500-1100
EMC class. C2, as per EN 61800-3	282	Additional RFI filters on the unit power line	Reduces electromagnetic interferences. Decrease the variable frequency drive (VFD) emission level according to C2 category requirements and allow its compliancy with use in first environment (so called, residential environment).	0500-1100
230V electrical plug	284	230V AC power supply source provided with plug socket and transformer (180 VA, 0,8 Amps)	Permits connection of a laptop or an electrical device during unit commissioning or servicing	0500-1100
Expansion tank	293	6 bar expansion tank integrated in the hydraulic module (requires hydraulic module option)	Easy and fast installation (plug & play), & Protection of closed water systems from excessive pressure	0500-1100
Fast Capacity Recovery	295	New software algorithms to allow quick restart and fast loading while preserving unit-reliability	Full capacity recovery in less than 5 minutes after power failure. Matches requirements of typical critical missions applications	0500-1100
Variable Water Flow control	299	hydraulic control function package that permits control of the water flow rate based on different possible logics (at customer choice): constant ?T, constant outlet pressure and "fixed-speed" control	When variable-speed pumps on the primary circuit, the VWF control modulates flow rate through the evaporator, minimising pump consumption while ensuring safe/ optimised chiller operation	0500-1100
Free-cooling dry-cooler control	313	Remote control of 09PE or 09VE dry-cooler based on a 0-10V signal. The 09PE or 09VE dry-cooler shall be selected with control cabinet option	Easy system management, extended control capabilities of a remote dry-cooler used in free-cooling mode	0500-1100
Compliance with UAE regulation	318	Additional label on the unit with rated power input, rated current and EER following AHRI 550/590	Compliance with ESMA standard UAE 5010-5 :2014.	0500-1100
Compliance with Qatar regulation	319	Specific nameplate on the unit with power supply 415 V+/-6%	Compliance with KAHRAMAA regulation in Qatar.	0500-1100
Hydraulic connection kit	325	Water piping on condenser and evaporator side	Easy installation	0500-1100
Compliance with Morocco regulation	327	Specifics documents according Morocco regulation	Conformance with Morocco regulations	0500-1100
Permanent magnet motor	329	Twin screw compressor with permanent magnet motor	Enhances the unit energy efficiency	0500-1100 already included on 30KAVP

HYDRAULIC MODULE

Typical water circuit diagram

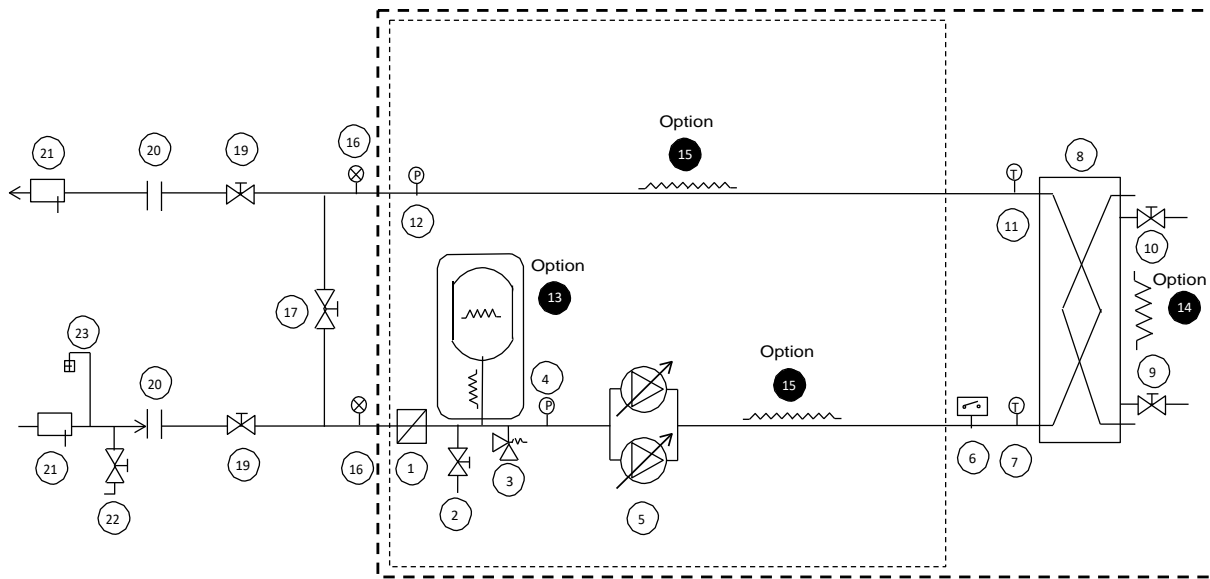

Legend

Components of the unit and hydraulic module

1. Screen filter (particle size of 1.2 mm)
2. Water drain tap
3. Relief valve
4. Pressure sensor
NOTE: Provides pressure information for the pump inlet (see Control manual)
5. Variable-speed dual pump (low or high pressure)
6. Water exchanger flow rate sensor
7. Temperature probe
NOTE: Provides temperature information for the water exchanger inlet (see Control manual)
8. Heat exchanger
9. Water purge (evaporator)
10. Air bleed (evaporator)
11. Temperature probe
NOTE: Provides temperature information for the water exchanger outlet (see Control manual)
12. Pressure sensor
NOTE: Provides pressure information for the water exchanger outlet (see Control manual)
13. Expansion tank (Option 293)
14. Electric resistance heater for heat exchanger frost protection (option 41A & 41B)
15. Electric resistance heater for hydraulic module frost protection (option 41B)

System components

16. Pressure gauge
17. Bypass valve for frost protection (if shut-down valves (item 19) are closed in winter)
18. Water flow control valve
19. Shut-off valve
20. Sleeve
21. Flexible connection
22. Charge valve
23. Air bleed

..... Included with the unit

----- hydraulic Module (unit with hydraulic module option (116A & 116W))

NOTES:

- The system must be protected against frost.
- The unit's hydraulic module and the water heat exchanger may be protected against freezing using electric heaters and heat trace cables (factory-fitted options 41A & 41B)
- The pressure sensors are assembled on connections without Schrader. Depressurise and drain the system before any work.

AVAILABLE STATIC PRESSURE (OPTIONS 116A, 116W)

**Low-pressure variable-speed dual pump
(Hydraulic module option 116A)**

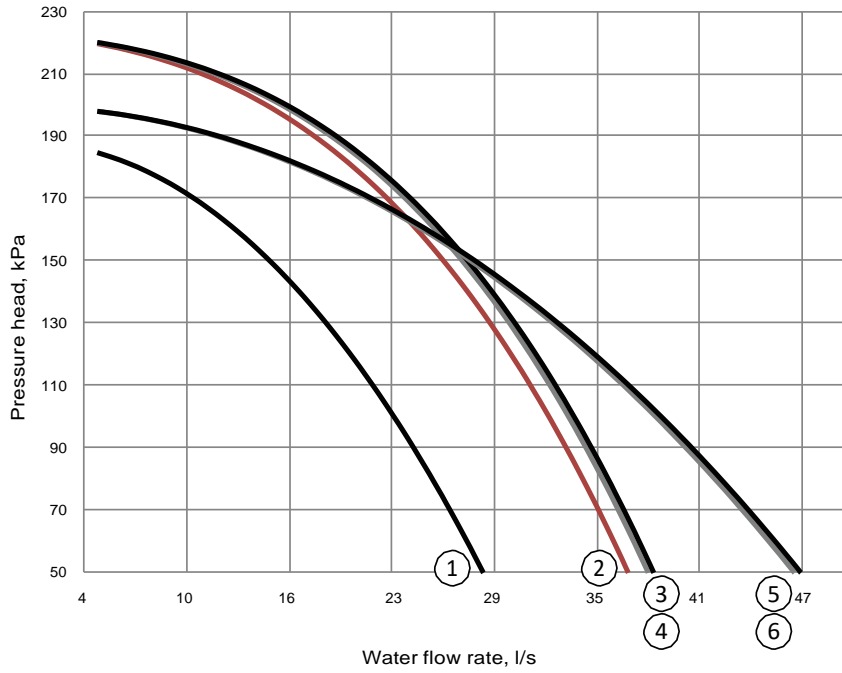

- 1 30KAV/30KAVP 500
- 2 30KAV/30KAVP 550
- 3 30KAV/30KAVP 600
- 4 30KAV/30KAVP 650
- 5 30KAV/30KAVP 720
- 6 30KAV/30KAVP 800

**High-pressure variable-speed dual pump
(Hydraulic module option 116W)**

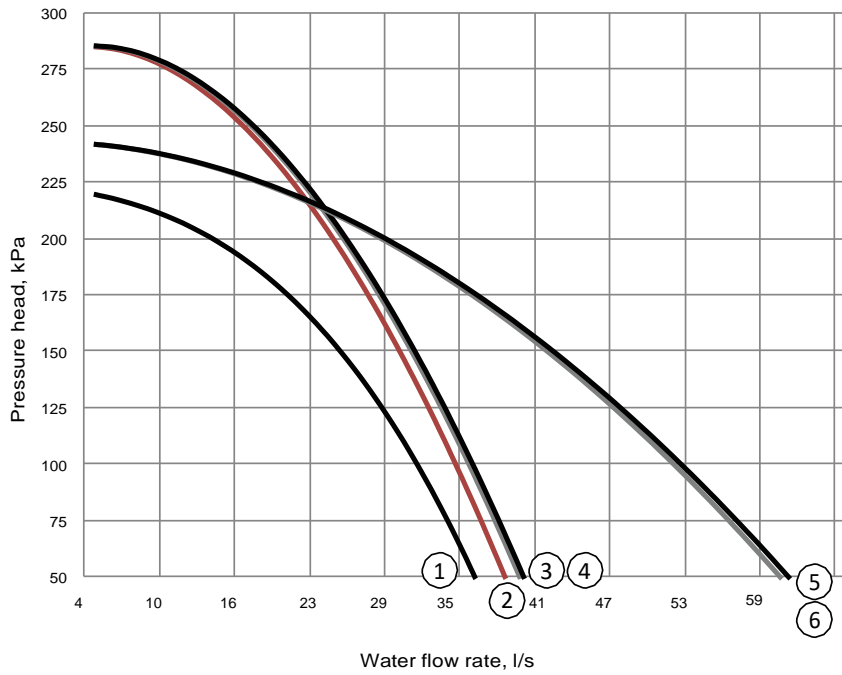

- 1 30KAV/30KAVP 500
- 2 30KAV/30KAVP 550
- 3 30KAV/30KAVP 600
- 4 30KAV/30KAVP 650
- 5 30KAV/30KAVP 720
- 6 30KAV/30KAVP 800

LOW TEMPERATURE BRINE SOLUTION (OPTION 6)

This option allows to reach very low brine temperatures according to values below and to maintain delta temperature in case of variable flow.

Variable water allows to adapt chilled water production to the real need and helps to save energy.

Lowest acceptable water flow must be validated with selection software.

30KAV/P 0500-1100

MEG40% : -15 °C (@ delta T 4K)

MEG35% : -12 °C (@ delta T 4K)

MPG35% : -10 °C (@ delta T 3K)

MPG35% : -8 °C (@ delta T 4K)

PARTIAL HEAT RECOVERY USING DESUPERHEATERS (OPTION 49)

This option enables free hot water to be produced using heat recovery by desuperheating the compressor discharge gases. The option is available for the whole 30KAV/KAVP range.

A plate heat exchanger is installed as standard, with the air-cooled exchanger coils on the compressor discharge line of each circuit.

Physical data

30KAV/KAVP								1000	
Unit length + options									
30KAV + option 49	mm							7962	
30KAV_option_119+ & 30KAVP + option 49	mm							10305	
Width	mm							2261	
Height	mm							2324	
Operating weight⁽¹⁾									
30KAV + option 49	kg							7222	
30KAV + option 49 + option 325 ⁽²⁾	kg							7386	
30KAV_option_119+ & 30KAVP + option 49	kg							7891	
30KAV_option_119+ & 30KAVP option 49 + option 325 ⁽²⁾	kg							8056	
Partial Heat recovery condenser		Braze Plates Heat Exchanger (BPHE)							
Circuit A								B320 LTL	
Circuit B								B320 LTL	
Water volume	l							48 / 48	
Water connections without option 325 ⁽²⁾		Victaulic® type							
Connection on heat reclaim condenser side	Pouce							4	
Outside tube diameter on heat reclaim condenser side	mm							114,3	
Connection on evaporator side	Pouce							8	
Outside tube diameter on evaporator side	mm							219,1	
Water connections with option 325 ⁽²⁾		Victaulic® type							
Connection on heat reclaim condenser side	Pouce							6	
Outside tube diameter on heat reclaim condenser side	mm							168,3	
Connection on evaporator side	Pouce							6	
Outside tube diameter on evaporator side	mm							168,3	

(1) Values are guidelines only. Refer to the unit name plate.

(2) Option 325 = Hydraulic connection kit.

PARTIAL HEAT RECOVERY USING DESUPERHEATERS (OPTION 49)

Operating limits

Desuperheater		Minimum	Maximum
Leaving water temperature during operation	°C	20	65
Air condenser		Minimum	Maximum
Outside operating temperature	°C	0 ⁽²⁾	46

(1) The maximum outside temperature is 0°C. With the winter operation option it is -20°C.

TOTAL HEAT RECLAIM (OPTION 50)

Suitable for heating, domestic hot water production, agriculture and food industry, industrial processes and other hot-water requirements.

With the total heat reclaim option it is possible to reduce the energy consumption bill considerably, when compared to conventional heating equipment such as fossil fuel boilers or electric water tanks.

Operating principle

If hot water production is required, the compressor discharge gases are directed towards the heat reclaim condenser. The refrigerant releases its heat to the hot water that leaves the condenser at a temperature of up to 60°C. In this way 100% of the heat rejected by the liquid chiller can be used to produce hot water. Hot water temperature control is ensured by the chiller Touch Pilot control that independently controls the reclaim operation of each refrigerant circuit.

NOTE: Heat reclaim is only possible, possible if the unit is producing cooling at the same time.

Condenser water temperature (°C)	Minimum	Maximum
Entering temperature during operation	18	60
Leaving temperature during operation	20	60

Note: If the evaporator leaving water temperature is below 4°C, a glycol-water solution or the frost protection option must be used.

In part-load operation, the limitation of the condenser leaving water temperature is due to the operating range of the screw compressor.

Operating limit

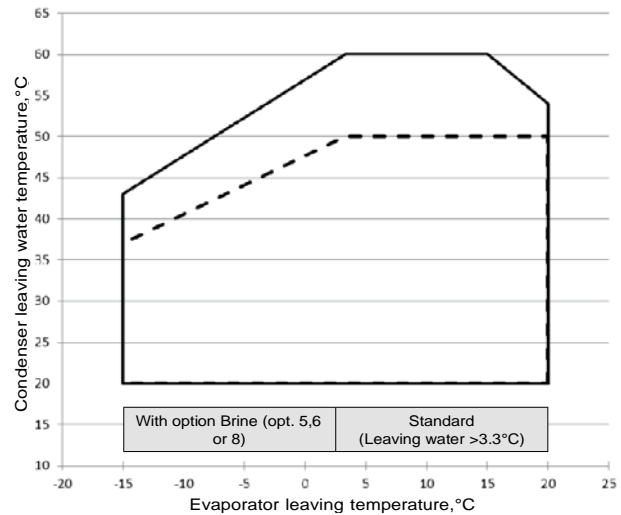

— Full load
- - - Partial load, approx. 30%

Physical data

30KAV/KAVP								1000
Unit length + options								
30KAV + option 50	mm						7962	
30KAV_option_119+ & 30KAVP + option 50	mm						10305	
Width	mm						2261	
Height	mm						2324	
Operating weight⁽¹⁾								
30KAV + option 50	kg						7451	
30KAV + option 50 + option 325 ⁽²⁾	kg						7662	
30KAV_option_119+ & 30KAVP + option 50	kg						8120	
30KAV_option_119+ & 30KAVP option 50 + option 325 ⁽²⁾	kg						8332	
Total Heat recovery condenser		Brazen Plates Heat Exchanger (BPHE)						
Circuit A							B427M1	
Circuit B							B427M1	
Water volume	l						48 / 48	
Water connections without option 325⁽²⁾		Victaulic® type						
Connection on heat reclaim condenser side	Pouce						4	
Outside tube diameter on heat reclaim condenser side	mm						114,3	
Connection on evaporator side	Pouce						8	
Outside tube diameter on evaporator side	mm						219,1	
Water connections with option 325⁽²⁾		Victaulic® type						
Connection on heat reclaim condenser side	Pouce						6	
Outside tube diameter on heat reclaim condenser side	mm						168,3	
Connection on evaporator side	Pouce						6	
Outside tube diameter on evaporator side	mm						168,3	

(1) Values are guidelines only. Refer to the unit name plate.
(2) Option 325 = Hydraulic connection kit.

TOTAL HEAT RECLAIM (OPTION 50)

30 KAV	Evaporator water outlet temperature °C	Condenser water outlet temperature °C (Delta T = 5K)																		
		30			40			45			50			55			60			
		Cc kW	Hr kW	Pi kW	Cc kW	Hr kW	Pi kW	Cc kW	Hr kW	Pi kW	Cc kW	Hr kW	Pi kW	Cc kW	Hr kW	Pi kW	Cc kW	Hr kW	Pi kW	
500	Pure water	15	518	601	115	516	613	129	512	622	143	504	625	158	492	585	175	478	543	192
		12	488	574	116	487	586	129	483	595	143	475	584	158	464	548	175	450	510	192
		7	439	529	117	438	540	130	434	549	144	427	520	159	417	488	175	404	457	192
		4	409	500	118	408	511	130	404	509	144	398	482	159	389	455	175	376	426	192
	Option8 (EG35%)	0	326	420	116	324	430	128	319	413	141	311	391	155	300	368	170			
	Option 5 (EG35%)	-4	294	390	116	294	392	128	292	376	141	286	359	155						
		-8	236	333	114	237	325	125	235	314	137	229	301	151						
550	Pure water	15	560	655	130	558	667	144	553	677	159	544	680	176	531	636	193	515	590	211
		12	529	626	131	527	638	145	522	648	159	514	636	175	502	595	192	486	554	210
		7	476	577	131	475	589	145	470	598	160	462	566	175	451	533	192	438	497	210
		4	444	547	131	443	558	145	438	555	160	431	526	175	421	495	192	408	464	209
	Option8 (EG35%)	0	359	464	129	357	475	142	352	455	156	343	432	171	331	406	187			
	Option 5 (EG35%)	-4	318	425	129	318	426	142	315	409	156	309	391	171						
		-8	251	359	127	252	350	138	248	337	151	242	322	166						
600	Pure water	15	615	706	129	615	720	143	610	730	158	602	735	174	590	688	191	575	636	209
		12	580	676	131	580	689	145	576	699	160	568	688	176	557	642	192	542	597	210
		7	522	622	133	522	635	147	518	646	162	511	610	177	500	573	194	486	534	212
		4	486	589	134	486	602	148	482	598	162	475	566	178	465	533	195	452	498	212
	Option8 (EG35%)	0	397	504	134	396	516	147	391	496	162	383	470	177	372	442	193			
	Option 5 (EG35%)	-4	345	456	135	345	457	147	343	439	162	337	418	177						
		-8	265	378	134	265	368	146	262	354	159	255	338	173						
650	Pure water	15	661	765	144	660	779	159	656	790	175	647	795	192	634	742	210	616	689	229
		12	624	732	146	624	745	161	619	756	176	611	743	193	598	696	211	581	645	230
		7	562	674	147	561	688	162	557	698	178	549	662	195	538	620	212	522	577	231
		4	523	638	148	523	651	163	519	649	179	511	614	195	500	577	213	486	539	231
	Option8 (EG35%)	0	432	551	148	430	563	162	425	541	178	417	513	194	405	483	211			
	Option 5 (EG35%)	-4	371	493	148	371	495	162	368	475	177	362	453	193						
		-8	281	407	147	281	395	160	277	380	174	269	362	189						
720	Pure water	15	713	831	163	711	846	179	706	857	196	696	861	214	681	802	232	662	742	252
		12	674	796	164	673	810	180	668	821	197	658	805	214	644	751	233	625	697	253
		7	608	734	165	607	748	181	602	759	198	593	717	216	580	672	234	563	625	254
		4	566	694	165	565	709	181	560	703	198	552	666	216	540	625	235	524	583	254
	Option8 (EG35%)	0	472	605	165	470	618	180	464	593	197	455	562	214	442	528	232			
	Option 5 (EG35%)	-4	400	537	165	400	537	180	395	515	196	388	490	213						
		-8	293	434	163	292	419	177	286	402	192	274	380	208						
800	Pure water	15	804	930	176	803	948	194	797	961	214	786	968	236	770	906	259	749	842	284
		12	761	892	178	760	908	196	755	922	216	744	907	237	728	850	261	708	792	286
		7	689	826	180	687	841	198	681	854	218	671	809	240	656	760	263	637	709	288
		4	643	784	182	642	799	200	636	796	219	626	751	241	611	708	264	593	662	289
	Option8 (EG35%)	0	549	696	183	546	710	201	540	683	220	528	647	241	512	609	264			
	Option 5 (EG35%)	-4	473	626	185	470	624	202	463	596	221	451	566	242						
		-8	372	530	186	366	510	202	357	487	220	343	461	240						

Cc = Cooling capacity
 Pi = Power input
 Hr = Heating recovery capacity
 Option 5 & 8 : Delta T = 4K
 Pure Water : Delta T=5K
 Outside temperature :35°

TOTAL HEAT RECLAIM (OPTION 50)

30 KAV	Evaporator water outlet temperature °C	Condenser water outlet temperature °C (Delta T = 5K)																		
		30			40			45			50			55			60			
		Cc kW	Hr kW	Pi kW	Cc kW	Hr kW	Pi kW	Cc kW	Hr kW	Pi kW	Cc kW	Hr kW	Pi kW	Cc kW	Hr kW	Pi kW	Cc kW	Hr kW	Pi kW	
900	Pure water	15	872	1019	200	870	1036	220	863	1050	242	850	1056	265	832	987	290	809	916	316
		12	827	977	202	825	994	222	817	1007	243	805	990	266	788	926	291	765	859	317
		7	749	905	204	747	922	223	739	935	245	728	883	268	711	829	293	690	773	319
		4	700	860	205	698	876	225	691	870	246	679	823	269	663	774	294	644	723	321
	Option8 (EG35%)	0	600	766	206	597	781	225	590	751	246	578	712	269	562	671	294			
	Option 5 (EG35%)	-4	517	688	207	513	686	226	504	654	247	491	620	269						
		-8	400	577	208	393	555	226	382	529	246	366	500	267						
1000	Pure water	15	970	1125	214	970	1146	237	963	1163	261	950	1173	288	931	1099	318	905	1022	350
		12	920	1080	216	919	1100	238	912	1116	263	899	1100	290	879	1031	319	855	958	351
		7	836	1002	220	833	1021	241	825	1036	266	812	981	293	793	922	322	769	864	354
		4	782	953	222	779	971	243	771	967	267	758	914	294	740	860	324	717	806	356
	Option8 (EG35%)	0	677	856	224	674	874	245	666	842	269	652	798	296	634	753	325			
	Option 5 (EG35%)	-4	596	782	227	590	780	248	578	742	271	562	703	298						
		-8	484	678	230	474	651	250	459	619	273	440	585	298						
1100	Pure water	15	1036	1212	239	1035	1234	263	1027	1251	289	1012	1260	318	991	1179	349	964	1093	382
		12	985	1164	241	983	1185	265	974	1201	291	959	1182	319	938	1106	350	912	1028	383
		7	895	1082	244	892	1101	267	883	1117	293	868	1057	322	848	992	353	823	926	386
		4	838	1029	245	835	1048	269	826	1041	295	811	986	323	792	927	354	768	867	388
	Option8 (EG35%)	0	725	923	247	722	942	270	714	908	296	701	863	324	682	814	355			
	Option 5 (EG35%)	-4	643	848	250	636	846	273	624	804	298	607	762	326						
		-8	518	732	252	508	703	274	493	668	298	472	632	326						

Cc = Cooling capacity
 Pi = Power input
 Hr = Heating recovery capacity
 Option 5 & 8 : Delta T = 4K
 Pure Water : Delta T=5K
 Outside temperature :35°

PHYSICAL DATA

Standard units and Units with EC fans option (17)

30KAV								1000		
Cooling										
Standard unit Full load performances*	CA1	Nominal capacity	kW						975	
		EER	kW/kW						2,98	
Standard unit Seasonal energy efficiency **		SEER 12/7°C Comfort low temp.	kWh/kWh						5,11	
		ηS cool 12/7°C	%						202	
		SEPR 12/7°C Process high temp.	kWh/kWh						6,67	
Unit + option 17 Seasonal energy efficiency **		SEER 12/7°C Comfort low temp.	kWh/kWh						5,19	
		ηS cool 12/7°C	%						204	
		SEPR 12/7°C Process high temp.	kWh/kWh						6,74	
Unit + option 329 Seasonal energy efficiency **		SEER 12/7°C Comfort low temp.	kWh/kWh						5,29	
		ηS cool 12/7°C	%						209	
		SEPR 12/7°C Process high temp.	kWh/kWh						6,83	
Unit + option 17 + option 329 Seasonal energy efficiency **		SEER 12/7°C Comfort low temp.	kWh/kWh						5,38	
		ηS cool 12/7°C	%						212	
		SEPR 12/7°C Process high temp.	kWh/kWh						6,91	
Sound levels										
Standard unit										
		Sound power ⁽¹⁾	dB(A)						98	
		Sound pressure at 10 m ⁽²⁾	dB(A)						65	
Unit + option 15⁽³⁾										
		Sound power ⁽¹⁾	dB(A)						97	
		Sound pressure at 10 m ⁽²⁾	dB(A)						64	
Unit + option 15LS⁽³⁾										
		Sound power ⁽¹⁾	dB(A)						93	
		Sound pressure at 10 m ⁽²⁾	dB(A)						60	
Dimensions										
Standard unit										
		Length	mm						7962	
		Width	mm						2261	
		Height	mm						2324	
Unit length + options										
		Options 49/50 ⁽³⁾	mm						7962	
		Options 116A/116W ⁽³⁾	mm						-	
Operating weight⁽⁴⁾										
		Standard unit	kg						6991	
		Unit + option 49 ⁽³⁾	kg						7222	
		Unit + option 50 ⁽³⁾	kg						7451	
		Unit + options 116A/116W ⁽³⁾	kg						-	-

* In accordance with standard EN14511-3:2013.

** In accordance with standard EN14825:2016, average climate

CA1 Cooling mode conditions: Evaporator water entering/leaving temperature 12°C/7°C, outside air temperature 35°C, evaporator fouling factor 0 m².K/W

ηS cool 12/7°C & SEER 12/7°C **Bold values compliant to Ecodesign regulation: (EU) No 2016/2281 for Comfort application**

SEPR 12/7°C **Bold values compliant to Ecodesign regulation: (EU) No 2016/2281 for Process application**

(1) in dB ref=10⁻¹² W, 'A' weighted. Declared dual-number noise emission values in accordance with ISO 4871 with an associated uncertainty of +/-3dB(A). Measured in accordance with ISO 9614-1 and certified by Eurovent.

(2) In dB ref 20μPa, 'A' weighted. Declared dual-number noise emission values in accordance with ISO 4871 with an associated uncertainty of +/-3dB(A). For information, calculated from the sound power Lw(A).

(3) Options: 15=Low noise level ; 15LS=Very low noise level ; 116A=LP VSD dual-pump hydraulic mod. ; 116W=HP VSD dual-pump hydraulic mod. 49=Partial heat recovery ; 50= Totale heat recovery ; 5=Medium Brine ; 6=Low Brine.

(4) Values are guidelines only. Refer to the unit name plate.

(5) For standard conditions. Depending on operating conditions, unit might have a different minimum capacity or cycle.



Eurovent certified values

PHYSICAL DATA

Standard units and Units with EC fans option (17)

30KAV									1000
Compressors		Inverter driven 06Z twin screw compressor with AC motor							
Circuit A	Quantity							1	
Circuit B	Quantity							1	
Unit minimum capacity ⁽⁵⁾	%							12	
Refrigerant⁽⁴⁾		R134a (GWP=1430, ODP=0)							
Circuit A	kg							92	
	teqCO ₂							132	
Circuit B	kg							93	
	teqCO ₂							133	
Refrigerant⁽⁴⁾ - Option 5⁽³⁾ (Medium Brine)		R134a (GWP=1430, ODP=0)							
Circuit A	kg							110	
	teqCO ₂							157	
Circuit B	kg							111	
	teqCO ₂							159	
Refrigerant⁽⁴⁾ - Option 6⁽³⁾ (Low Brine)		R134a (GWP=1430, ODP=0)							
Circuit A	kg							97	
	teqCO ₂							138	
Circuit B	kg							98	
	teqCO ₂							140	
Oil		SW220							
Circuit A	l							23	
Circuit B	l							23	
Unit control		SmartView with 7 inch coloured touch screen interface							
Languages		10 languages (DE, EN, ES, FR, IT, NL, PT, TR, TU + one on customer choice)							
Smart energy metering		Standard feature							
Wireless connectivity		Option							
Expansion valve		Electronic expansion valve							
Air heat exchanger		Novation™ Micro Channel Heat Exchanger							
Fans									
Standard unit		Inverter driven Flying Bird™ VI fans with AC motor							
Unit + option 17		Inverter driven Flying Bird™ VI fans with EC motor							
Quantity								12	
Maximum total air flow	l/s							71160	
Maximum rotation speed	r/s							16,0	
Maximum total air flow + option 15LS ⁽³⁾	l/s							57840	
Maximum rotation speed + option 15LS ⁽³⁾	r/s							13,2	
Water heat exchanger		Flooded shell and tube heat exchanger							
Water volume	l							165	
Max. water-side operating pressure without hydraulic module	kPa							1000	
Hydraulic module (option)		Double pump, screen filter, relief valve, water drain valve, pressure sensors, expansion tank (option), heaters (option)							
Pump		Inverter driven dual pumps with AC motor							
Expansion vessel volume	l						- - -		
Max. water-side operating pressure	kPa						- - -		
Water connections		Victaulic® type							
Without options 116A/116W⁽³⁾									
Connections	pouces							8	
Outside tube diameter	mm							219,1	
With options 116A/116W⁽³⁾									
Connections	pouces						- - -		
Outside tube diameter	mm						- - -		
Casing paint		Colour code RAL 7035							

(3) Options: 15=Low noise level ; 15LS=Very low noise level ; 116A=LP VSD dual-pump hydraulic mod. ; 116W=HP VSD dual-pump hydraulic mod. 49=Partial heat recovery ; 50= Totale heat recovery ; 5=Medium Brine ; 6=Low Brine

(4) Values are guidelines only. Refer to the unit name plate.

(5) For standard conditions. Depending on operating conditions, unit might have a different minimum capacity or cycle.

ELECTRICAL DATA

Standard units

30KAV									1000
Power circuit supply									
Nominal voltage	V-ph-Hz	400-3-50							
Voltage range	V	360-440							
Control circuit supply		24 V via internal transformer							
Maximum operating input power⁽¹⁾									
Standard unit	kW							437	
Unit + option 16	kW							466	
Power factor at maximum power⁽¹⁾⁽²⁾		0,91-0,93							
Displacement Power Factor (Cos Phi)		>0,98							
Total harmonic distortion (THDi) ⁽¹⁾⁽³⁾		35-45							
Nominal operating current draw⁽⁴⁾									
Standard unit	A							524	
Maximum operating current draw (Un)⁽¹⁾									
Standard unit	A							679	
Unit + option 16	A							724	
Maximum operating current draw (Un-10%)									
Standard unit	A							733	
Unit + option 16	A							782	
Start-up current									
Standard unit	A							399	

(1) Values obtained at operation with maximum operating power input (data given on the unit nameplate)

(2) Value decreases when load lowers

(3) May vary according to the installation's short circuit ratio

THDi increases when load lowers. But the highest impact on the installation occurs when the current is maximum. Therefore compliance of the installation regarding voltage harmonic distortion at PCC (per IEC61000-2-4 or other standard) shall be usually checked at max load in order to cover all load conditions.

(4) Standardised EUROVENT conditions, water-cooled exchanger water inlet/outlet = 12°C/7°C, outdoor air temperature = 35°C.

ELECTRICAL DATA

Units with option permanent magnet motor (329), option High energy efficiency (119) and option High energy efficiency+ (119+)

30KAV options 119/119+									1000
Power circuit supply									
Nominal voltage	V-ph-Hz	400-3-50							
Voltage range	V	360-440							
Control circuit supply									
24 V via internal transformer									
Maximum operating input power⁽¹⁾									
Unit + option 119	kW								426
Unit + option 119+	kW								422
Unit + option 119 + option 16	kW								455
Unit + option 119+ + option 16	kW								451
Unit + option 329	kW								423
Unit + option 329 + option 16	kW								452
Unit + option 329 + option 119	kW								412
Unit + option 329 + option 119 + option 16	kW								441
Power factor at maximum power^{(1) (2)}									
0,91-0,93									
Displacement Power Factor (Cos Phi)									
>0,98									
Total harmonic distortion (THDi) ^{(1) (3)}									
%									
35-45									
Nominal operating current draw⁽⁴⁾									
Unit + option 119	A								466
Unit + option 119+	A								460
Unit + option 329	A								508
Maximum operating current draw (Un)⁽¹⁾									
Unit + option 119	A								662
Unit + option 119+	A								656
Unit + option 119 + option 16	A								707
Unit + option 119+ + option 16	A								701
Unit + option 329	A								658
Unit + option 329 + option 16	A								703
Unit + option 329 + option 119	A								641
Unit + option 329 + option 119 + option 16	A								686
Maximum operating current draw (Un-10%)									
Unit + option 119	A								707
Unit + option 119+	A								701
Unit + option 119 + option 16	A								762
Unit + option 119+ + option 16	A								756
Unit + option 329	A								712
Unit + option 329 + option 16	A								761
Unit + option 329 + option 119	A								692
Unit + option 329 + option 119 + option 16	A								741
Start-up current									
Unit + option 119	A								390
Unit + option 119+	A								387
Unit + option 329	A								376

(1) Values obtained at operation with maximum operating power input (data given on the unit nameplate)

(2) Value decreases when load lowers

(3) May vary according to the installation's short circuit ratio

THDi increases when load lowers. But the highest impact on the installation occurs when the current is maximum. Therefore compliance of the installation regarding voltage harmonic distortion at PCC (per IEC61000-2-4 or other standard) shall be usually checked at max load in order to cover all load conditions."

(4) Standardised EUROVENT conditions, water-cooled exchanger water inlet/outlet = 12°C/7°C, outdoor air temperature = 35°C.

Compressor electrical data

Compressor	I Max (A) ⁽¹⁾ Standard	I Max (A) ⁽¹⁾ Option 16	F max (Hz) ⁽²⁾	Inverter type ⁽³⁾
06ZFC2T3AA06013	364	389	95	D4h

(1) Maximum compressor operating current draw over the entire range when powered at rated voltage. May be lower depending on the unit size.

(2) Maximum compressor frequency other the entire range. This frequency can be limited to a lower value depending on the unit size.

(3) Mechanical inverter type : defines inverter weight and dimensions.

Distribution of compressors per circuit

Compressor 30KAV	Circuit	500	550	600	650	720	800	900	1000	1100
06ZFC2T3AA06013	A								1	
	B								1	

ELECTRICAL DATA

Electrical notes

- 30KAV-30KAVP 0500 to 1100 units have a single power connection point located immediately upstream of the main disconnect switch.
- The two electrical cabinets contain:
 - A supply disconnecting component.
 - All or part of the equipment protecting the circuits inside the machine from short circuits.⁽¹⁾
 - Frequency inverters for the compressors, fans, and pumps,
 - The switching equipment for the heaters and fans for the electrical equipment
 - The control devices.
- Connections to the building installation:

Electrical installation and all the connections to the network must be carried out in compliance with all standards applicable to the installation location. Generally, the recommendations of the International Electrotechnical Commission document (IEC60364) are accepted as compliance with the requirements of the installation guidelines. 30KAV units are designed and built to ensure compliance with these guidelines. The European standard EN 60204-1 (corresponds to IEC 60204-1: Machine safety - Electrical equipment of machines - Part 1: General requirements) was specifically taken into account when the electrical equipment was designed.

NOTES

- The standard EN60204-1 enables the requirements of the Machinery Directive to be met.
- Annex B of standard EN 60204-1 is intended to define the electrical characteristics used for the operation of the machines. Those described below apply alongside the other information provided in this document:
 1. Environment
The classification of the environment is specified in standard IEC60364:
 - Outdoor installation⁽²⁾,
 - Ambient temperature range for the standard machine: from -20°C to +44°C (48°C)⁽³⁾,
 - Ambient temperature range for the machine with option 16: from -20°C to +48°C (55°C)⁽³⁾,
 - Altitude: up to 1000 m (2000m)⁽⁴⁾
 - Presence of solid foreign bodies: Class AE3 (no significant dust present)⁽²⁾,
 - Presence of corrosive and polluting substances, class AF1 (negligible),
 - Competence of personnel: BA4 (trained personnel).
 2. Compatibility for low-frequency conducted disturbances according to class 2 levels as per IEC61000-2-4 standard:
 - Power supply frequency variation: +1Hz
 - Phase imbalance: 2%
 - Total Voltage Harmonic Distortion (THDV): 8%
 3. The neutral wire (N) must not be connected directly to the unit (if necessary, use a transformer).
 4. Overcurrent protection of the power supply conductors is not provided with the unit.
 5. The factory-fitted disconnect switch is of a type suitable for power interruption in compliance with EN 60947-3 (equivalent to IEC 60947-3).

6. The units are designed for connection to TN networks (IEC 60364). In IT networks, the use of filters integrated into the frequency inverter(s) prevents the machines from fulfilling their intended purpose. In addition, the equipment's short-circuit holding current characteristics have been modified. Provide a local earth, consult competent local organisations to complete the electrical installation.
 7. Electromagnetic environment: the classification of the electromagnetic environment is described in the standard EN61800-3 (equivalent to IEC 61800-3):
 - Immunity to external interference defined by the second environment(5)
 - Interference emission as defined in category C3(6)
- The frequency inverters integrated into 30KAV machines have harmonic currents which are a source of interference. An analysis may be required to verify if this interference exceeds the compatibility limits of the other devices connected to the same power supply network. The compatibility levels inside an electrical installation, that must be met at the in-plant coupling point (IPC) to which other loads are connected, are described in standard IEC 61000-2-4.
 - Leakage currents: if protection by monitoring the leakage currents is necessary to ensure the safety of the installation, the presence of DC voltage component as well as additional derived currents introduced by the use of frequency inverters in the unit must be considered. In particular it is recommended that the differential protection devices are:
 - suitable for protection of DC and AC circuitry
 - of reinforced immunity protection types and/or set at a threshold value not lower than 150 mA

NOTE: if particular aspects of an installation require different specifications to those listed above (or which are not listed), always contact your Carrier representative.

- (1) With the exception of machines equipped with option 70D, a part of the short circuit protection is not provided and must be carried out on the installation, in compliance with the instructions given in this document.
- (2) The required protection level for this class is IP43BW (according to the reference standard IEC 60529). All 30KAV units are classified as IP44CW, and fulfil this protection condition.
- (3) The values in brackets correspond to operation with degraded thermal performances.
- (4) Above 1000m, the maximum temperature must be reduced by 0.5K for every additional 100m up to 2000m (for the hydraulic module, see the section on "Electrical data notes for the hydraulic module"),
- (5) - Example of installations included in the first environment: commercial and residential buildings.
 - Example of installations included in the second environment: industrial zones, technical premises powered from a dedicated transformer.
- (6) Category C3 is suitable for use in an industrial environment and is not designed for use in a public low-voltage system that supplies residential locations. As an option, conformity with category C2 permits this type of installation.

PART LOAD PERFORMANCES

SEER for comfort chillers (in accordance with EU ECODESIGN)

The SEER (Seasonal energy efficiency ratio) permits the evaluation of the average energy efficiency of comfort chillers, based on multiple operating conditions (load variation from 0% to 100%). From 1st January 2018, Tier 1 and from 1st January 2021, Tier 2, European member states will impose minimum SEER values to meet the requirements of Eco-design directive for ENER Lot 21 comfort cooling chillers. The Ecodesign Directive aims at minimizing the environmental impact of energy-related products under consideration of their full lifecycle.

EU ECODESIGN MEPS(*) for air-cooled chillers		Tier 1 (from 01/01/2018)	Tier 2 (from 01/01/2021)
SEER for comfort Chillers < 400 kW	kWh/kWh	3,80	4,09
SEER for comfort Chillers > 400 kW	kWh/kWh	4,09	4,55



SEER is : the new metric for chillers in **comfort cooling applications.**

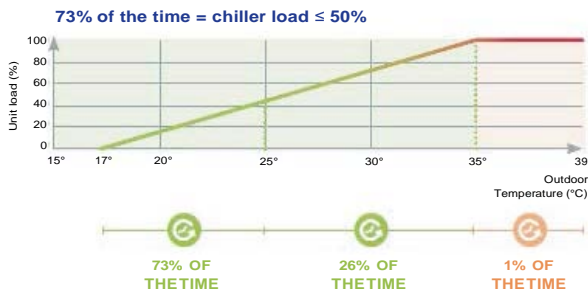

SEPR for process chillers (in accordance with EU ECODESIGN)

The SEPR (Seasonal energy performance ratio) permits the evaluation of the average energy efficiency of process chillers, based on multiple operating conditions (load variation from 80% to 100%). From 1st January 2018, Tier 1 and from 1st January 2021, Tier 2, European member states will impose minimum SEPR values for process chillers to meet the requirements of Eco-design directive for ENER Lot 21 for high temperature process chillers (7°C to 12°C) and from 1st July 2018, for ENER Lot 1 for low temperature process chillers (-25°C to -8°C) and medium temperature process chillers (-8°C to 7°C). The Ecodesign Directive aims at minimizing the environmental impact of energy-related products under consideration of their full lifecycle. All process chillers marked with a CE label must meet the determined SEPR (Seasonal Energy Performance Ratio) value stipulated in EU Directive.



SEPR is the new metric for chillers in **industrial process cooling applications.**

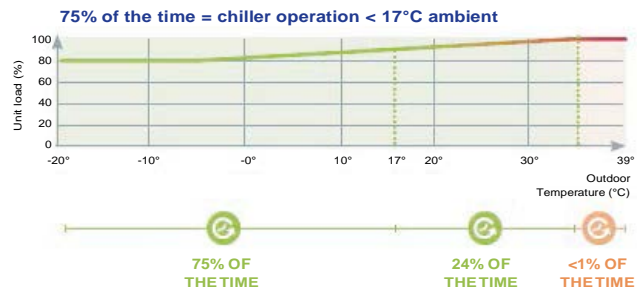

EU ECODESIGN MEPS(*) for air-cooled chillers		Tier 1 (from 01/07/2016)	Tier 2 (from 01/07/2018)
SEPR for medium temperature chillers < 300 kW	kWh/kWh	2,24	2,58
SEPR for medium temperature chillers > 300 kW	kWh/kWh	2,80	3,22

EU ECODESIGN MEPS(*) for air-cooled chillers		Tier 1 (from 01/01/2018)	Tier 2 (from 01/01/2021)
SEPR for high temperature Process Chillers < 400 kW	kWh/kWh	4,50	5,00
SEPR for high temperature Process Chillers > 400 kW	kWh/kWh	5,00	5,50

(*) Minimum Efficiency Performance Standards set by EU member states to comply with EU Ecodesign directive.

SOUND SPECTRUM

Acoustic spectrum and power of the standard unit

30KAV Standard unit		Octave bands (Hz) ⁽¹⁾						Sound power ⁽²⁾		
		125	250	500	1k	2k	4k	8k		
1000	dB	90	94	98	92	89	81	78	dB(A)	98

(1) In dB ref=10⁻¹² W, as a guideline. Measured in accordance with ISO 9614-1.

(2) In dB ref=10⁻¹² W, weighting (A), with uncertainty +/-3 dB. Measured in accordance with ISO 9614-1 and certified by Eurovent.

Acoustic spectrum and power of the unit + option 15 (Low noise level)

30KAV Unit + option 15		Octave bands (Hz) ⁽¹⁾						Sound power ⁽²⁾		
		125	250	500	1k	2k	4k	8k		
1000	dB	93	92	92	94	88	88	83	dB(A)	97

(1) In dB ref=10⁻¹² W, as a guideline. Measured in accordance with ISO 9614-1.

(2) In dB ref=10⁻¹² W, weighting (A), with uncertainty +/-3 dB. Measured in accordance with ISO 9614-1 and certified by Eurovent.

Acoustic spectrum and power of the unit + option 15LS (Very low noise level)

30KAV Unit + option 15LS		Octave bands (Hz) ⁽¹⁾						Sound power ⁽²⁾		
		125	250	500	1k	2k	4k	8k		
1000	dB	88	91	90	89	82	83	80	dB(A)	93

(1) In dB ref=10⁻¹² W, as a guideline. Measured in accordance with ISO 9614-1.

(2) In dB ref=10⁻¹² W, weighting (A), with uncertainty +/-3 dB. Measured in accordance with ISO 9614-1 and certified by Eurovent.

SOUND SPECTRUM

Acoustic spectrum and power of 30KAV with option 119 (High energy efficiency) or option 119+ (High energy efficiency+)

Acoustic spectrum and power of 30KAVP

30KAV_option_119/119+ & 30KAVP	Octave bands (Hz) ⁽¹⁾							Sound power ⁽²⁾	
	125	250	500	1k	2k	4k	8k		
1000	91	95	99	93	89	82	78	dB(A)	98

(1) In dB ref= 10^{-12} W, as a guideline. Measured in accordance with ISO 9614-1.

(2) In dB ref= 10^{-12} W, weighting (A), with uncertainty +/-3 dB. Measured in accordance with ISO 9614-1 and certified by Eurovent.

Acoustic spectrum and power of units with option 15 (Low noise level) and option 119 (High energy efficiency) or option 119+ (High energy efficiency+)

Acoustic spectrum and power of 30KAVP with option 15

30KAV_option_119/119+ & 30KAVP: option 15	Octave bands (Hz) ⁽¹⁾							Sound power ⁽²⁾	
	125	250	500	1k	2k	4k	8k		
1000	93	92	93	94	89	88	83	dB(A)	98

(1) In dB ref= 10^{-12} W, as a guideline. Measured in accordance with ISO 9614-1.

(2) In dB ref= 10^{-12} W, weighting (A), with uncertainty +/-3 dB. Measured in accordance with ISO 9614-1 and certified by Eurovent.

Acoustic spectrum and power of units with option 15LS (Very low noise level) and option 119 (High energy efficiency) or option 119+ (High energy efficiency+)

Acoustic spectrum and power of 30KAVP with option 15LS

30KAV_option_119/119+ & 30KAVP: option 15LS	Octave bands (Hz) ⁽¹⁾							Sound power ⁽²⁾	
	125	250	500	1k	2k	4k	8k		
1000	85	91	90	89	82	83	80	dB(A)	93

(1) In dB ref= 10^{-12} W, as a guideline. Measured in accordance with ISO 9614-1.

(2) In dB ref= 10^{-12} W, weighting (A), with uncertainty +/-3 dB. Measured in accordance with ISO 9614-1 and certified by Eurovent.

OPERATING RANGE

Evaporator water temperature		Minimum	Maximum
Entering temperature at start-up	°C	-	45 ⁽¹⁾
Entering temperature during operation	°C	6,8	25
Leaving temperature during operation	°C	3,3 ⁽²⁾	20
Standard unit	°C	3,3 ⁽²⁾	20
Unit + option 8 ⁽³⁾	°C	-4	20
Unit + option 5 ⁽³⁾	°C	-8	20
Unit + option 6 ⁽³⁾	°C	-15	20
Condenser air temperature		Minimum	Maximum
Storage	°C	-20	68
Operation			
Standard unit	°C	-20 ⁽⁴⁾	48 ⁽¹⁾
Unit + option 16 ⁽³⁾	°C	-20 ⁽⁴⁾	55 ⁽¹⁾

NOTES:

- The use of brine or antifreeze protection option is required if the water outlet temperature is below 4 °C.
- If the air temperature is below 0 °C, a glycol/water solution or the freeze protection option must be used.
- (1) Operating at partial load
- (2) According to the type of installation and air temperature
- (3) Option 16 = High ambient temperature, 8=Light Brine ; 5=Medium Brine ; 6=Low Brine
- (4) Option 41A mandatory for start-ups below -5 °C

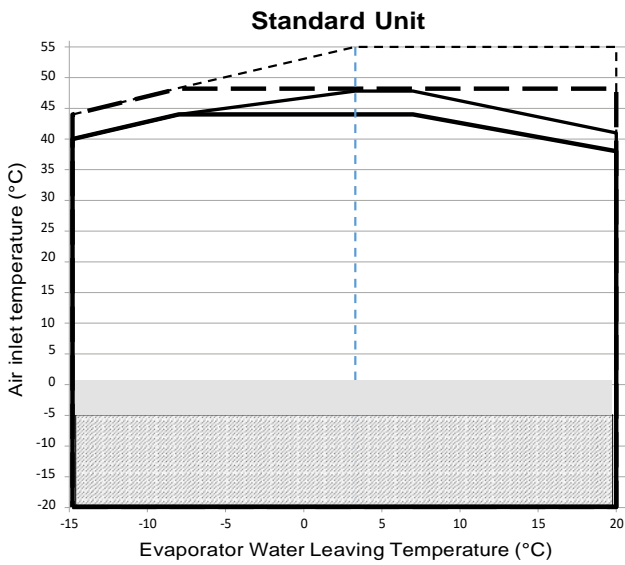

NOTES:

- Evaporator $\Delta T = 4K$.
- These ranges are given for indicative purpose. Check the operating range from Carrier electronic catalogue.

Legend

- Operating range, standard units
- Below 0 °C air temperature the unit must either be equipped with the evaporator frost protection option 41A, or the water loop must be protected against frost by using a frost protection solution (by the installer).
- For start-ups with air temperature below -5 °C, the machine must be equipped with option 41A.

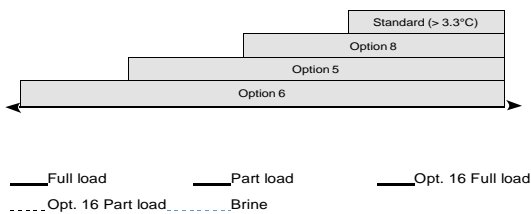

DIMENSIONS/CLEARANCES

30KAV 720 opt. 119/119+ 30KAV 900 & 1000 without Hydraulic module
30KAVP 720 without Hydraulic module

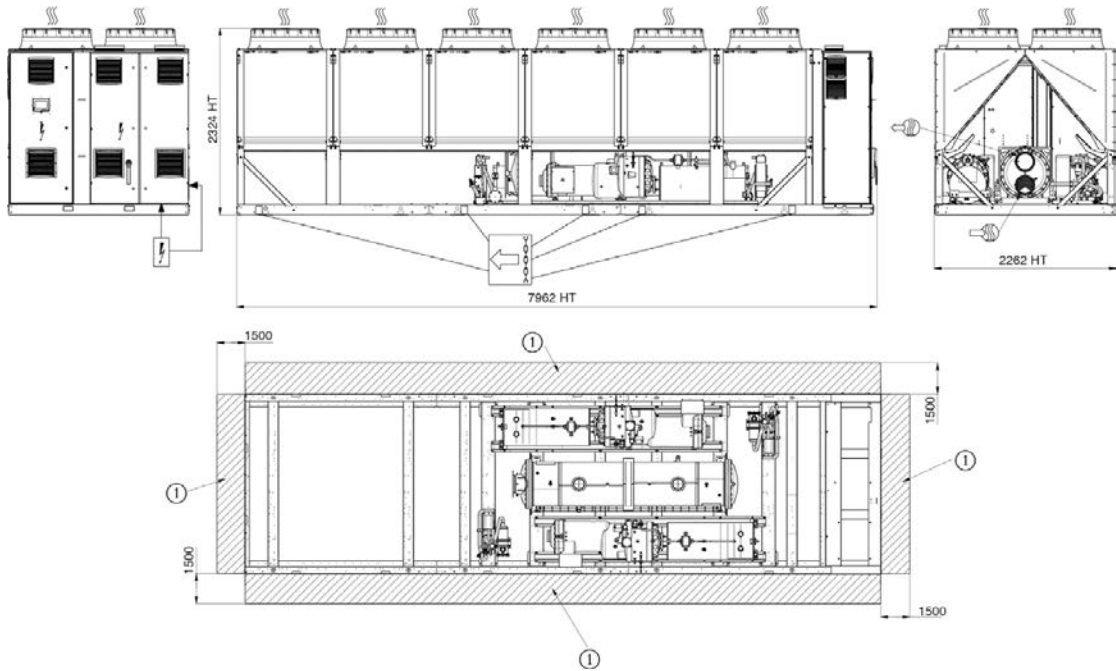



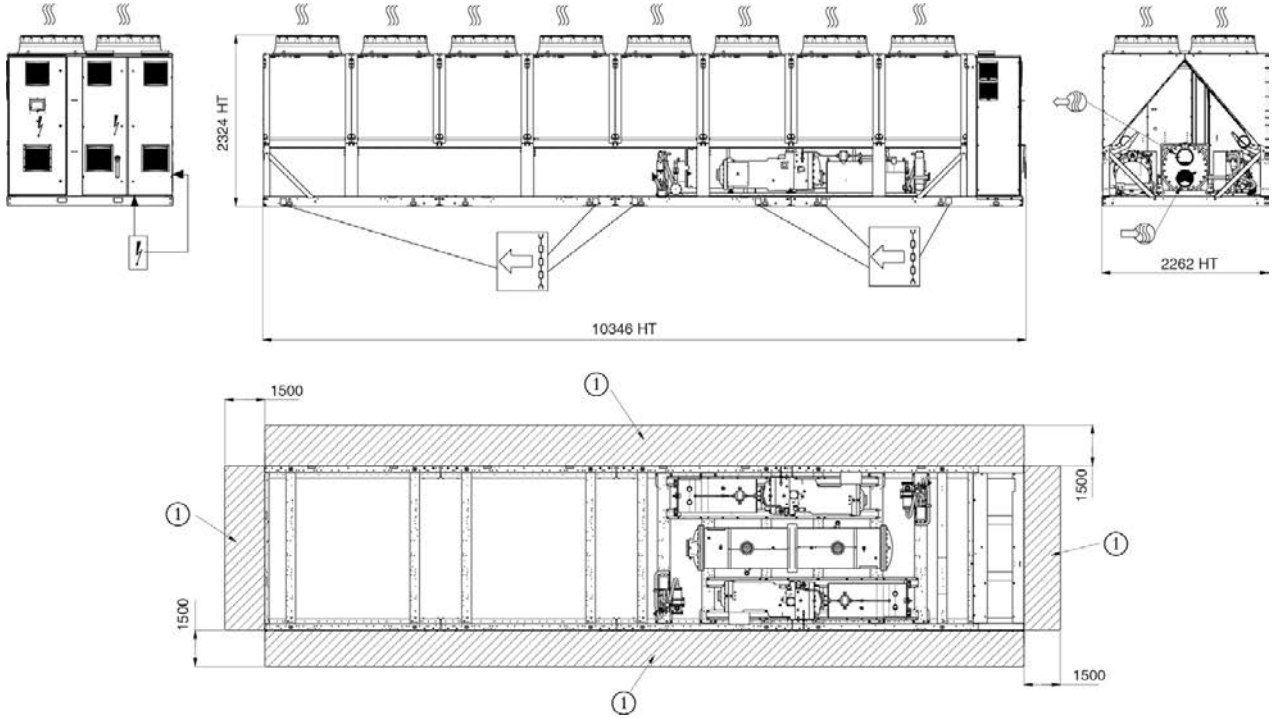

DIMENSIONS/CLEARANCES

30KAV 1000 & 1100 opt. 119/119+ 30KAVP 1000 & 1100



Legend

All dimensions are given in mm.

-  Required clearances for maintenance (see note)
-  Water inlet for standard unit
-  Water outlet for standard unit
-  Air outlet – do not obstruct
-  Power electrical connection

Multiple chiller installation

It is recommended to install multiple chillers in a single row, arranged as shown in the example below, to avoid recycling of warm air from one unit to another.



If the situation at the site does not permit this arrangement, contact your Carrier distributor to evaluate the various possible arrangements. In certain situations an accessory (supplied loose at the time of purchase) can be added.

NOTES:

Drawings are not contractually binding.

Before designing an installation, consult the certified dimensional drawings, available on request.

For the positioning of the fi points, weight distribution and centre of gravity coordinates please refer to the dimensional drawings.

If any unit(s) are close to walls, please refer to chapter "Distance to the wall" of this document to determine the space required.

Distance to the wall

To ensure correct operation for most cases:

- If $h < H$ (2,3 m), S minimum = 3 m
- If $h > H$ ou $S < 3$ m, contact your Carrier distributor to evaluate the various possible arrangements. In certain situations an accessory (supplied loose at the time of purchase) can be added.

